

19th – 29th July 2018
Bratislava, SLOVAKIA
Prague, CZECH REPUBLIC

www.50icho.eu

THEORETICAL PROBLEMS

Country:	
Name as in passport:	
Student code:	
Language:	



50th IChO 2018

International Chemistry Olympiad
SLOVAKIA & CZECH REPUBLIC

BACK TO WHERE IT ALL BEGAN



Table of Contents

Instructions.....	2
Physical constants and equations	3
Problem 1. DNA	5
Problem 2. Repatriation of remains in the middle ages.....	14
Problem 3. Emerging electro-mobility	22
Problem 4. Column chromatography of radioactive copper	30
Problem 5. Bohemian garnet.....	34
Problem 6. Let's go mushrooming	41
Problem 7. Cidofovir	47
Problem 8. Caryophyllene	54



Instructions

- This theoretical exam booklet contains 62 pages.
- You may begin writing as soon as the **Start** command is given.
- You have **5 hours** to complete the exam.
- All results and answers must be clearly written **in pen in their respective designed areas** on the exam papers. Answers written outside the answer boxes will not be graded.
- You were provided with 3 sheets of scratch paper. If you need more, use the backside of the exam sheets. Remember that **nothing outside the designed areas will be graded**.
- The periodic table and visible light spectrum are not part of this booklet; they are provided separately.
- Use only the pen and calculator provided.
- **The official English version** of the exam booklet is available upon request and serves for clarification only.
- If you need to leave the exam room (to use the toilet or have a snack), wave the blue IChO card. The exam supervisor will come to accompany you.
- The supervisor will announce a 30-minute warning before the **Stop** command.
- You must stop your work immediately when the **Stop** command is announced. Failure to stop writing by $\frac{1}{2}$ minute or longer will lead to nullification of your theoretical exam.
- After the **Stop** command has been given, place your exam booklet back in your exam envelope and wait at your seat. The exam supervisor will come to collect the envelope.



Physical constants and equations

Avogadro's constant:	$N_A = 6.022 \times 10^{23} \text{ mol}^{-1}$
Universal gas constant:	$R = 8.314 \text{ J K}^{-1} \text{ mol}^{-1}$
Speed of light:	$c = 2.998 \times 10^8 \text{ m s}^{-1}$
Planck's constant:	$h = 6.626 \times 10^{-34} \text{ J s}$
Faraday constant:	$F = 9.6485 \times 10^4 \text{ C mol}^{-1}$
Standard pressure:	$p = 1 \text{ bar} = 10^5 \text{ Pa}$
Normal (atmospheric) pressure:	$p_{\text{atm}} = 1.01325 \times 10^5 \text{ Pa}$
Zero of the Celsius scale:	273.15 K
Mass of electron:	$m_e = 9.109 \times 10^{-31} \text{ kg}$
Unified atomic mass unit:	$u = 1.6605 \times 10^{-27} \text{ kg}$
Ångström:	$1 \text{ Å} = 10^{-10} \text{ m}$
Electronvolt:	$1 \text{ eV} = 1.602 \times 10^{-19} \text{ J}$
Watt:	$1 \text{ W} = 1 \text{ J s}^{-1}$
Ideal gas equation:	$pV = nRT$
The first law of thermodynamics:	$\Delta U = q + W$
Power input for electrical device:	$P = UI$ where U is voltage and I electric current
Enthalpy:	$H = U + pV$
Gibbs free energy:	$G = H - TS$ $\Delta G^\circ = -RT \ln K = -zFE_{\text{cell}}^\circ$ $\Delta G = \Delta G^\circ + RT \ln Q$
Reaction quotient Q for a reaction $a A + b B \rightleftharpoons c C + d D$:	$Q = \frac{[C]^c [D]^d}{[A]^a [B]^b}$
Entropy change:	$\Delta S = \frac{q_{\text{rev}}}{T}$ where q_{rev} is heat for the reversible process
Heat change for temperature-independent c_m :	$\Delta q = n c_m \Delta T$ where c_m is molar heat capacity



Van 't Hoff equation:

$$\frac{d \ln K}{dT} = \frac{\Delta_r H_m}{RT^2} \Rightarrow \ln \left(\frac{K_2}{K_1} \right) = -\frac{\Delta_r H_m}{R} \left(\frac{1}{T_2} - \frac{1}{T_1} \right)$$

Henderson–Hasselbalch equation:

$$\text{pH} = \text{p}K_a + \log \frac{[\text{A}^-]}{[\text{HA}]}$$

Nernst–Peterson equation:

$$E = E^\circ - \frac{RT}{zF} \ln Q$$

Energy of a photon:

$$E = \frac{hc}{\lambda}$$

Relation between E in eV and in J:

$$E/\text{eV} = \frac{E/\text{J}}{q_e/C}$$

Lambert–Beer law:

$$A = \log \frac{I_0}{I} = \epsilon l c$$

Wavenumber:

$$\tilde{\nu} = \frac{\nu}{c} = \frac{1}{2\pi c} \sqrt{\frac{k}{\mu}}$$

Reduced mass μ for a molecule AX:

$$\mu = \frac{m_A m_X}{m_A + m_X}$$

Energy of harmonic oscillator:

$$E_n = h\nu \left(n + \frac{1}{2} \right)$$

Arrhenius equation:

$$k = A e^{-\frac{E_a}{RT}}$$

Rate laws in integrated form:

Zero order:

$$[\text{A}] = [\text{A}]_0 - kt$$

First order:

$$\ln[\text{A}] = \ln[\text{A}]_0 - kt$$

Second order:

$$\frac{1}{[\text{A}]} = \frac{1}{[\text{A}]_0} + kt$$



Theoretical Problem 1 7% of the total	Question	1.1	1.2	1.3	1.4	1.5	1.6	Total
	Points	5	5	4	12	12	24	62
	Score							

Problem 1. DNA

Palindromic sequences are an interesting class of DNA. In a palindromic double-stranded DNA (dsDNA) species, the sequence of one strand read in the 5'→3' direction matches the 5'→3' reading on the complementary strand. Hence, a palindromic dsDNA consists of two identical strands that are complementary to each other. An example is the so-called Drew–Dickerson dodecanucleotide (1):

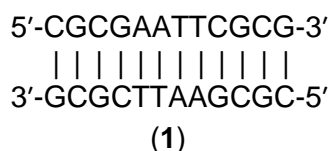

- 1.1 How many different palindromic double-stranded DNA dodecanucleotides (i.e., dsDNA species with twelve base pairs) exist?

The choice of the first, second, third, fourth, fifth and sixth nucleotide in one strand is arbitrary; the seventh through twelfth nucleotides in the same strand are determined by the condition of self-complementarity. There are always 4 options (C, G, A, T) for the first through six nucleotide. Hence, the total number of palindromic DNA hexanucleotides is $4 \times 4 \times 4 \times 4 \times 4 \times 4 = 4^6 = 4\,096$.

5 points in total

Any numerical result above scores full marks.

No explanation of the calculation is needed to score full marks as long as the result is correct.

Example of a partially correct solution:

4 points if the student writes $4 \times 4 \times 4 \times 4 \times 4 \times 4$ explicitly, but he/she gives an incorrect final result (e.g., due to an improper use of a calculator).

Examples of incorrect solutions that do not score any marks:

The student counts uracil as the fifth possibility, yielding 15 625 octanucleotides.

The student counts four possibilities for each of the twelve nucleotides, i.e. they ignore the condition of self-complementarity, yielding 16 777 216 dodecanucleotides.

0 points for any other result.

- 1.2 How many different palindromic double-stranded DNA undecanucleotides (i.e., dsDNA species with eleven base pairs) exist?

0. There is no palindromic dsDNA with an odd number of base pairs.

5 points

No explanation is needed.

0 points for any other result.



The melting temperature of dsDNA, T_m is defined as the temperature at which 50% of the original amount of DNA double strands are dissociated into separate strands.

- 1.3 Consider the Drew–Dickerson dodecanucleotide (1). Assume that a G–C nucleobase pair contributes to the DNA duplex stability more than an A–T pair does. What is the probability that its T_m increases when a single randomly selected base pair is replaced by a G–C pair?

Probability

The thermodynamic stability, and thus the melting temperature increases whenever an A–T pair is replaced by a G–C pair. The probability of randomly drawing one of the 4 A–T pairs from the Drew–Dickerson dodecanucleotide containing 12 base pairs is

$$4/12 = 1/3 \sim 0.333 \sim 0.33 \text{ or } 33.3\% \sim 33\%$$

4 points in total

Any of the numerical results above scores full marks.

No additional explanation is needed to score full marks.

Example of a partially correct solution:

2 points if the student declares 4/12 but they present an incorrect final result (e.g. $4/12 = 0.25$).

Examples of incorrect solutions that do not score any marks:

The student counts only two A–T pairs rather than four, yielding the probability of 2/12.

The student incorrectly counts the total number of nucleotide pairs.

Let us analyze the thermodynamics of formation of double-helical DNA from single strands, and its dependence on the length of the DNA and on the temperature. The equilibrium constant of association of single strands to form dsDNA differs for palindromic and non-palindromic dsDNA. A solution of dsDNA with the initial concentration of $c_{\text{init}} = 1.00 \times 10^{-6} \text{ mol dm}^{-3}$ was heated to T_m and equilibrium was reached.

- 1.4 Calculate the equilibrium constant of **association** of single strands at T_m for both non-palindromic and palindromic DNA.

Non-palindromic dsDNA

Calculation:

The association reaction of a non-palindromic dsDNA reads



and the equilibrium constant of association takes the form

$$K_{\text{np}} = \frac{[\text{dsDNA}]}{\frac{c_0}{[\text{ssDNA1}]} \times \frac{c_0}{[\text{ssDNA2}]}}$$

where c_0 is the standard concentration of 1.00 mol dm^{-3} and the lower index np stands for “non-palindromic”.

At T_m , one half of the initial dsDNA concentration has melted to ssDNA, so

$$[\text{dsDNA}] = [\text{ssDNA1}] = [\text{ssDNA2}] = 1/2 c_{\text{init}}$$



which yields

$$K_{np}(T_m) = \frac{\frac{1/2 c_{init}}{c_0}}{\frac{1/2 c_{init}}{c_0} \times \frac{1/2 c_{init}}{c_0}} = \frac{c_0}{1/2 c_{init}} = \frac{1.00 \{ \text{mol dm}^{-3} \}}{1/2 \times 1.00 \times 10^{-6} \{ \text{mol dm}^{-3} \}} = 2.00 \times 10^6$$

$K =$

Palindromic dsDNA

Calculation:

The association reaction of a palindromic dsDNA reads



and the equilibrium constant of association is

$$K_p = \frac{\frac{[\text{dsDNA}]}{c_0}}{\left(\frac{[\text{ssDNA}]}{c_0} \right)^2}$$

where c_0 is the standard concentration, and the lower index p stands for "palindromic".

At T_m , one half of the initial dsDNA concentration has melted into two ssDNAs with identical sequences, so

$$\begin{aligned} [\text{dsDNA}] &= 1/2 c_{init} \\ [\text{ssDNA}] &= 2 \times [\text{dsDNA}] = c_{init} \end{aligned}$$

which yields

$$K_p(T_m) = \frac{\frac{1/2 c_{init}}{c_0}}{\left(\frac{c_{init}}{c_0} \right)^2} = \frac{1/2 c_0}{c_{init}} = \frac{1/2 \times 1 \times 1.00 \text{ mol dm}^{-3}}{1.00 \times 10^{-6} \text{ mol dm}^{-3}} = 5.0 \times 10^5$$

$K =$

2 points for the association reactions (1 point each)

10 points for the calculation of the association constant with c_{init} (5 points each)

Some of the steps may be condensed or performed implicitly, and the association reactions may not be presented explicitly. As long as the derivation is correct, full marks are scored for all of the elementary steps.

K is considered correct if given as unitless number or with the unit of $\text{mol}^{-1} \text{ dm}^3$. Thus, failure to introduce unitless concentrations explicitly does not lead to any deduction provided the result is numerically correct.

Examples of grading partially correct solutions:

Dissociation is considered rather than association, and the calculation is otherwise correct
deduction of 3 points

Wrong numeric value of $K(T_m)$ in spite of the correct symbolic result, due to, e.g., an improper use of a calculator
deduction of 2 points each

A correct expression for K is written initially, but there is an error in the derivation
deduction of 2 pts per each K affected, max. 2 points

K is correct numerically, but the unit is wrong (e.g., mol dm^{-3})
deduction of 2 points, enforced max. once

The score for any sub-task may not be negative.



The mean contributions to the Gibbs energy of association of two single strands to form dsDNA were estimate over a certain range of experimental conditions, and they amount to $-6.07 \text{ kJ mol}^{-1}$ per one G–C pair, and $-1.30 \text{ kJ mol}^{-1}$ per one A–T pair present in a dsDNA.

- 1.5 How many base pairs are there in the **shortest** dsDNA oligonucleotide that has T_m above 330 K? At this T_m , consider the following values of the equilibrium constant of association of single strands to form a dsDNA: $K_{np} = 1.00 \times 10^6$ for a non-palindromic dsDNA, $K_p = 1.00 \times 10^5$ for a palindromic dsDNA. Is the shortest oligonucleotide palindromic or non-palindromic?

Calculation of the number of base pairs:

K is related to the association Gibbs energy as $\Delta G_{np}^\circ = -RT \ln K_{np}$, so the Gibbs energy at T_m is

$$\begin{aligned} \Delta G_{np}^\circ(T_m) &= -RT \ln K_{np}(T_m) = \\ &= -8.314 \text{ J K}^{-1} \text{ mol}^{-1} \times 330 \text{ K} \times \ln(1.00 \times 10^6) = -37.9 \text{ kJ mol}^{-1} \end{aligned}$$

The shortest oligonucleotide will be obtained if C–G-only dsDNA is considered, because C–G pairs are more stable than A–T pairs.

Then, the smallest number of base pairs is obtained by dividing the Gibbs energy by the contribution of one C–G pair, which for a non-palindromic dsDNA is:

$$n_{np} = \frac{-37.9 \text{ kJ mol}^{-1}}{-6.07 \text{ kJ mol}^{-1}} = 6.2$$

The needed length of a non-palindromic dsDNA: **7**

For a palindromic dsDNA, the Gibbs energy at T_m is

$$\begin{aligned} \Delta G_p^\circ(T_m) &= -RT \ln K_p(T_m) = \\ &= -8.314 \text{ J K}^{-1} \text{ mol}^{-1} \times 330 \text{ K} \times \ln(1.00 \times 10^5) = -31.6 \text{ kJ mol}^{-1}, \end{aligned}$$

and the number of base pairs is

$$n_p = \frac{-31.6 \text{ kJ mol}^{-1}}{-6.07 \text{ kJ mol}^{-1}} = 5.2$$

The needed length of a palindromic dsDNA: **6**

The shortest oligonucleotide is

- palindromic (P)
 non-palindromic (NP).

A smaller number of base pairs was obtained under the assumption of a palindromic dsDNA. Therefore, we conclude that the shortest dsDNA that has T_m above 330 K has a palindromic sequence of 6 C–G pairs.

5 points for the calculations of Gibbs energies

2 points for the consideration of C–G-only DNA (either stated explicitly, or just considering $-6.07 \text{ kJ mol}^{-1}$ for the contribution of a single base pair to the Gibbs energy of association; not awarded if the value for A–T DNA is considered)

3 points for the calculation of the number of base pairs



2 points for the decision on a palindromic sequence

Full marks will be given if palindromic dsDNA is considered correctly. The non-palindromic case is not required explicitly.

If only non-palindromic case is considered, 50% of the marks may be scored for the calculation (max. 5 points in total)

-2 points for the wrong numeric value of n_p in spite of the correct symbolic result and logics, e.g. due to an improper use of a calculator, or due to a gross rounding error

Finally, let us leave the simplified idea of base pairs contributing individually to the **association** of DNA strands. The Gibbs energy of this process may be considered explicitly dependent on temperature. The dependence of the inverse T_m of the Drew–Dickerson dodecanucleotide (1) on the logarithm of the initial duplex concentration c_{init} is shown below. (Note: a standard concentration $c_0 = 1 \text{ mol dm}^{-3}$ is introduced.)

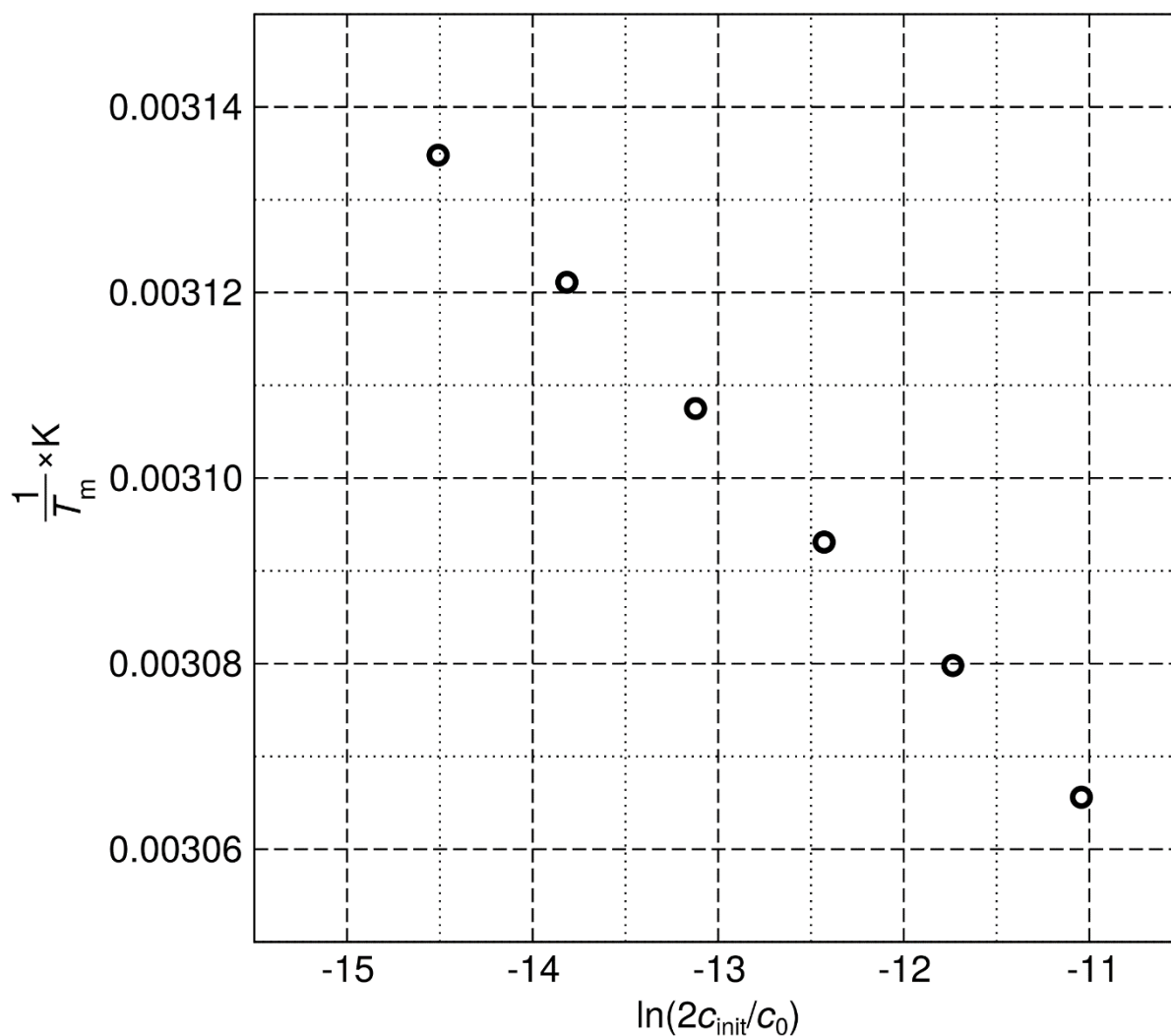



$c_{\text{init}} / 10^{-6} \text{ mol dm}^{-3}$	0.25	0.50	1.00	2.0	4.0	8.0
T_m / K	319.0	320.4	321.8	323.3	324.7	326.2

- 1.6 Calculate the standard enthalpy ΔH° and the standard entropy ΔS° of the association of DNA single strands to form the palindromic double-stranded Drew–Dickerson dodecanucleotide (1). Assume that ΔH° and ΔS° do not vary with temperature.

Calculation:

Start from the definition of ΔG° and its relation to the equilibrium constant:

$$\Delta G^\circ = \Delta H^\circ - T\Delta S^\circ$$

$$\Delta G^\circ = -RT \ln K$$

Combination of the expressions leads to

$$\Delta H^\circ - T\Delta S^\circ = -RT \ln K$$

Division by $T \times \Delta H^\circ$ yields

$$\frac{1}{T} - \frac{\Delta S^\circ}{\Delta H^\circ} = -\frac{R}{\Delta H^\circ} \ln K$$

so that, specifically for T_m

$$\frac{1}{T_m} = \frac{\Delta S^\circ}{\Delta H^\circ} - \frac{R}{\Delta H^\circ} \ln K_m$$

where K_m is the equilibrium constant at the melting temperature.

For the palindromic Drew–Dickerson dodecanucleotide, the concentrations of dsDNA and ssDNA at the melting temperature may be expressed in terms of the initial duplex concentration c_{init}

$$[\text{dsDNA}] = 0.5 c_{\text{init}}$$

$$[\text{ssDNA}] = c_{\text{init}}$$

and the equilibrium constant at the melting temperature follows as

$$K_m = \frac{0.5 \frac{c_{\text{init}}}{c_0}}{\left(\frac{c_{\text{init}}}{c_0}\right)^2} = \frac{1}{2 \frac{c_{\text{init}}}{c_0}}$$

This may be cast into the equation above for the inverse melting temperature, yielding a linearized concentration dependence (note the “plus” sign), which corresponds to the plot in this task directly:

$$\frac{1}{T_m} = \frac{\Delta S^\circ}{\Delta H^\circ} + \frac{R}{\Delta H^\circ} \ln \left(2 \frac{c_{\text{init}}}{c_0} \right)$$

The slope $R/\Delta H^\circ$ and the intercept $\Delta S^\circ/\Delta H^\circ$ may be obtained



- either graphically from the plot – **method 1**,
- or by solving a system of 2 linear equations using any 2 data points – **method 2**.

Method 1: The dependence in the plot is strongly linear, and it is very easy to draw a straight line passing the centre of each of the circles representing data points. Then, values of the linear function may be read, e.g., at $\ln(2 \frac{c_{\text{init}}}{c_0}) = -15$, ca. 0.003145 K^{-1} , and at $\ln(2 \frac{c_{\text{init}}}{c_0}) = -11$, ca. 0.003065 K^{-1} . From these numerical values, the slope follows as

$$\text{slope} = \frac{0.003065 \text{ K}^{-1} - 0.003145 \text{ K}^{-1}}{-11 - (-15)} = -0.000020 \text{ K}^{-1}$$

and the intercept has to be re-calculated to abscissa equal to zero, e.g., as

$$\text{intercept} = 0.003065 \text{ K}^{-1} + (0 - (-11)) \times (-0.000020 \text{ K}^{-1}) = 0.002845 \text{ K}^{-1}$$

Method 2: For instance, considering the first and the last point, we obtain:

$$\text{the first point: } \frac{1}{T_m} = \frac{1}{319.0 \text{ K}} = 3.135 \times 10^{-3} \text{ K}^{-1} \quad \ln(2 \frac{c_{\text{init}}}{c_0}) = \ln(2 \times 0.25 \times 10^{-6}) = -14.5$$

$$\text{the last point: } \frac{1}{T_m} = \frac{1}{326.2 \text{ K}} = 3.066 \times 10^{-3} \text{ K}^{-1} \quad \ln(2 \frac{c_{\text{init}}}{c_0}) = \ln(2 \times 8.0 \times 10^{-6}) = -11.0$$

A system of two linear equations follows as

$$3.135 \times 10^{-3} \text{ K}^{-1} = \frac{\Delta S^\circ}{\Delta H^\circ} - 14.5 \times \frac{R}{\Delta H^\circ}$$

$$3.066 \times 10^{-3} \text{ K}^{-1} = \frac{\Delta S^\circ}{\Delta H^\circ} - 11.0 \times \frac{R}{\Delta H^\circ}$$

which yields the solution

$$\frac{\Delta S^\circ}{\Delta H^\circ} = 2.849 \times 10^{-3} \text{ K}^{-1} \quad \text{and} \quad \frac{R}{\Delta H^\circ} = -2.0 \times 10^{-5} \text{ K}^{-1}$$

Common to Methods 1 and 2: The desired thermodynamic quantities follow from there:

$$\Delta H^\circ = \frac{R}{\text{slope}} = \frac{8.314}{-0.000020} \text{ J mol}^{-1} = -416 \text{ kJ mol}^{-1}$$

$$\Delta S^\circ = R \times \frac{\text{intercept}}{\text{slope}} = 8.314 \times \frac{0.002845}{-0.000020} \text{ J K}^{-1} \text{ mol}^{-1} = -1.18 \text{ kJ K}^{-1} \text{ mol}^{-1}$$

Alternative route:

It is also possible to consider the linearized dependence implicitly.

After the combination of equalities for ΔG° , K_m may be expressed in terms of c_{init} :

$$\Delta H^\circ - T_m \Delta S^\circ = RT_m \ln(2 \frac{c_{\text{init}}}{c_0})$$

Then, a set of 2 such equations for 2 different concentrations

$$\Delta H^\circ - T_{m1} \Delta S^\circ = RT_{m1} \ln(2 \frac{c_{\text{init},1}}{c_0})$$



$$\Delta H^\circ - T_{m2}\Delta S^\circ = RT_{m2} \ln \left(2 \frac{c_{\text{init},2}}{c_0} \right)$$

may be solved for 2 unknowns, ΔH° and ΔS° .

For instance, multiplication of the equations with T_{m2} and T_{m1} , respectively, followed by the subtraction of equations leads to

$$\Delta H^\circ = R \frac{T_{m1}T_{m2}}{T_{m2} - T_{m1}} \ln \frac{c_{\text{init},1}}{c_{\text{init},2}}$$

and a plain subtraction of equations leads to

$$\Delta S^\circ = R \frac{T_{m1} \ln \left(2 \frac{c_{\text{init},1}}{c_0} \right) - T_{m2} \ln \left(2 \frac{c_{\text{init},2}}{c_0} \right)}{T_{m2} - T_{m1}}$$

Or, ΔS° may be obtained by casting ΔH° into one of the equations being solved:

$$\Delta S^\circ = \frac{\Delta H^\circ}{T_{m1}} + R \ln 2 \frac{c_{\text{init},1}}{c_0}$$

The desired quantities follow as $\Delta H^\circ = -420 \text{ kJ mol}^{-1}$ and $\Delta S^\circ = -1.2 \text{ kJ mol}^{-1} \text{ K}^{-1}$.

24 points in total

15 points for the symbolic derivations

- 3 points for the combination of the expressions for ΔG°
- 3 points for the rearrangement to yield the linear relationship between T_m and K_m
- 3 points for the concentrations of the dsDNA and ssDNA at T_m
- 3 points for the expression of K_m in terms of c_{init} for a palindromic sequence
- 3 points for the linear relationship between T_m and $\ln 2c_{\text{init}}$

9 points for the numerical calculations

Note: the least-squares linear fit to the data series leads to the following results including the standard deviations: slope = $(-19.97 \pm 0.08) \times 10^{-6}$, intercept = $(2.845 \pm 0.001) \times 10^{-3}$.

Method 1:

- Perform a least-squares linear fit on the pocket calculator, or
- read-off of the slope & intercept for the linear dependence (ref.: least-sq. linear fit)
- 6 points within a margin of 5σ (i.e., $-20.39 < 10^6 \text{ slope} < -19.55$ & $2.840 < 10^3 \text{ intercept} < 2.850$)
- 3 points within a margin of 10σ (i.e., $-20.81 < 10^6 \text{ slope} < -19.13$ & $2.835 < 10^3 \text{ intercept} < 2.855$)
- partial marks will be scored in case the slope & intercept are given with different deviations or if one is missing

3 points for the calculation of ΔH° & ΔS° from the slope & intercept

Method 2:

- 3 points for the setup of the system of two equations
- up to 6 points for the calculation of ΔH° and ΔS° , considering the accuracy requirements given above

Alternative route – symbolic derivations up to 18 points, numerical calculations up to 6 points

Symbolic derivations:

- 3 points for the combination of the expressions for ΔG° (a)
- 3 points for the concentrations of the dsDNA and ssDNA at the melting temperature (b)
- 3 points for the expression of K_m in terms of c_{init} for a palindromic sequence (c)



3 points for the setup of the system of two equations (d)

3 points for the expression for ΔH° (e)

3 points for the expression for ΔS° (f)

9 points for a correct application of Van 't Hoff equation, yielding an expression for ΔH° (a+d+e)

Numerical calculations: maximum 6 points considering the accuracy requirements given above

General remarks

Some of the steps in the derivation and in the calculation may be taken implicitly or simultaneously.

As long as they are correct, full marks will be scored for each of the partial steps.

Failure to write unitless concentrations explicitly and consistently does not lead to any deduction as long as the concentrations are in mol dm^{-3} and numerically correct.



Theoretical Problem 2 8% of the total	Question	2.1	2.2	2.3	2.4	2.5	2.6	2.7	2.8	Total
	Points	1	4	4	2	6	10	17	14	58
	Score									

Problem 2. Repatriation of remains in the middle ages

At ambient temperatures, racemization is a slow reaction. As such, it can be used for dating biological objects and, moreover, for studying their thermal history. Let us take L-isoleucine (L-Ile) ((2*S*,3*S*)-2-amino-3-methylpentanoic acid) as an example. It isomerizes on the α -carbon and forms (2*R*,3*S*)-2-amino-3-methylpentanoic acid, also known as D-*allo*-isoleucine. As the configuration changes on only one of the two stereogenic centres, this process is called epimerization rather than racemization.

2.1 Choose all true statements.

- D-*allo*-isoleucine and L-isoleucine have the same values of specific optical rotation but they have different melting points.
- D-*allo*-isoleucine has an identical absolute value of specific optical rotation as L-isoleucine but the sign is opposite. The melting point is the same for both isomers.
- D-*allo*-isoleucine and L-isoleucine have different values of specific optical rotation but they have the same melting points.
- D-*allo*-isoleucine and L-isoleucine have different values of specific optical rotation and different melting points.
- D-*allo*-isoleucine is not optically active.

1 point for the correct answer

-1 point for each incorrect answer

0 points minimum score

2.2 Assign the absolute configurations for each stereoisomer of isoleucine.

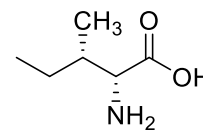
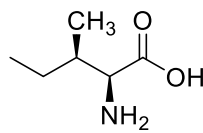
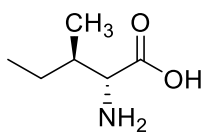
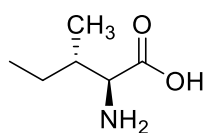

C 2*S*,3*R* (L-*allo*-isoleucine)

D 2*R*,3*S* (D-*allo*-isoleucine)

A 2*S*,3*S* (L-isoleucine)

B 2*R*,3*R* (D-isoleucine)

1 point for each correct answer



- 2.3 The equilibrium constant K_{ep} for L-isoleucine epimerization has the value of 1.38 (at 374 K). If we set molar Gibbs free energy of L-isoleucine $G_m^\circ = 0 \text{ kJ mol}^{-1}$, determine the Gibbs free energies for all structures **A–D** from question 2.2 at 374 K.

A kJ mol^{-1}

B kJ mol^{-1}

C kJ mol^{-1}

D kJ mol^{-1}

A $G_m^\circ = 0 \text{ kJ mol}^{-1}$ (L-isoleucine)

B $G_m^\circ = 0 \text{ kJ mol}^{-1}$ (**B** is a mirror image of **A** with identical physical properties)

C $G_m^\circ = -RT \ln K_{ep} = -1.00 \times 10^3 \text{ J mol}^{-1}$

D $G_m^\circ = -1.00 \times 10^3 \text{ J mol}^{-1}$ (**D** is a mirror image of **C** with identical physical properties)

4 points in total, 1 point for each numerical value A, B, C, D

No explanation is needed to score full marks as long as the results are correct.

0 points for incorrect sign.

- 2.4 If we take into account stereoisomerism at all stereocentres, what is the maximum possible number of the stereoisomers of the tripeptide Ile-Ile-Ile?

The number of stereoisomers is 2^N , where N is the number of stereogenic centres.

For Ile-Ile-Ile, $N = 6$, so there are $2^6 = 64$ stereoisomers.

2 points for the numerical result (either 2^6 or 64). No explanation is needed.

1 point if the student correctly declares 2^6 but the final result is numerically incorrect.

Example of an incorrect solution that do not score any marks:

The student incorrectly counts the number of stereocenters.

At the start of the epimerization, we can neglect the reverse reaction. The epimerization then follows the first-order kinetics:

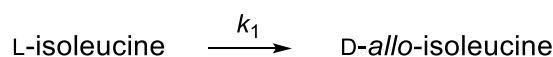

The value of the rate constant at 374 K is $k_1(374 \text{ K}) = 9.02 \times 10^{-5} \text{ h}^{-1}$ and at 421 K it is $k_1(421 \text{ K}) = 1.18 \times 10^{-2} \text{ h}^{-1}$.

In the following calculation, shorten the concentration of L-isoleucine to [L] and of D-*allo*-isoleucine to [D].

We can define a quantity *de* (diastereomeric excess):

$$de = \frac{[L] - [D]}{[L] + [D]} \times 100(\%).$$

- 2.5 Let us boil L-isoleucine for 1 943 hours at 374 K. What is the value of *de* (with three significant figures) for L-isoleucine a) before boiling and b) after boiling?



a) Before boiling

Calculation:

Before boiling, the de is:

$$de = \frac{[L]_0 - [D]_0}{[L]_0 + [D]_0} \times 100(\%)$$

Because $[D]_0 = 0$, the de of native L-isoleucine before boiling is 100%.

$de =$ % (with three significant figures)

b) After boiling

Calculation:

First, we have to calculate the concentration ratio $\frac{[L]}{[L]_0}$ from the first-order rate equation

$$\frac{[L]}{[L]_0} = e^{-k_1 t} = 0.839$$

$$\text{so } [D] = 0.161 [L]_0$$

and $de = \frac{0.839 - 0.161}{0.839 + 0.161} \times 100\% = 67.8\%$ (with three significant figures)

$de =$ % (with three significant figures)

Number of significant figures is not evaluated

2 points for the de before boiling

No additional explanation is needed to score full marks.

After boiling:

1 point for the equation for the concentration ratio from the first-order rate equation

1 point for the relation between the concentration of D-allo-isoleucine and L-isoleucine

2 points for the numerical result

If de is given as 0.678, full marks are scored.

Some of the steps may be performed implicitly. As long as the result is correct, full marks are scored for all elementary steps.

No points are scored if the calculations are not provided

2.6 How long does it take to convert 10% of L-isoleucine to D-*allo*-isoleucine at 298 K?

Calculation:

We need to evaluate the rate constant at 298 K. It can be evaluated from the Arrhenius equation:

$$\ln k = \ln A - \frac{E_a}{RT}$$

We get $\ln A$ and E_a from the values of k at two temperatures (374 K and 421 K)

$$\ln k (374 \text{ K}) = \ln 9.02 \times 10^{-5} [\text{h}^{-1}] = -9.313 = \ln A - \frac{E_a}{R \times 374}$$

$$\ln k (421 \text{ K}) = \ln 1.18 \times 10^{-2} [\text{h}^{-1}] = -4.444 = \ln A - \frac{E_a}{R \times 421}$$



It follows that

$$\ln A = -9.313 + \frac{E_a}{R \times 374} = -4.444 + \frac{E_a}{R \times 421}$$

from which $E_a = 136 \text{ kJ mol}^{-1}$.

$\ln A$ is from the equation at 374 K

$$\ln(A[\text{h}^{-1}]) = -9.313 + \frac{E_a}{R \times 374} = 34.4$$

For k at 298 K we then have:

$$\ln(k(298 \text{ K})[\text{h}^{-1}]) = \ln A - \frac{E_a}{R \times 298} = 34.4 - \frac{136 \times 10^3}{R \times 298} = -20.5$$

$$k(298 \text{ K}) = 1.25 \times 10^{-9} \text{ h}^{-1}$$

It follows from the rate equation that

$$\ln \frac{[L]}{[L]_0} = -kt$$

$$\ln 0.90 = -1.25 \times 10^{-9} t$$

$$t = 8.42 \times 10^7 \text{ h} = 9\,610 \text{ years}$$

$t =$ years

2 points for the formulation of the set of two equations

2 points for the correct formulae for $\ln A$ and E_a (1 point each)

2 points for the correct numerical values of $\ln A$ and E_a (1 point each)

2 points for the calculation of the rate constant at 298 K (1 point for the formula, 1 point for the numerical value)

2 points for the calculation of time

Full marks will be given if the time is calculated correctly using a wrong value of k based on the correct formula.

Some of the steps may be performed implicitly. As long as the result is correct, full marks are scored for all elementary steps. Full marks will be given for numerical calculations of time and rate constants within margins $k(298 \text{ K}) = 1.25 \times 10^{-9} \text{ h}^{-1} \pm 0.1 \times 10^{-9} \text{ h}^{-1}$, $t = 9\,610 \text{ years} \pm 850 \text{ years}$.

No points are scored if the calculations are not provided.

In fact, the reverse reaction cannot be neglected. The correct kinetic scheme is expressed as

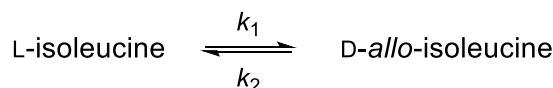

Let us define the deviation of concentration from its equilibrium value $[L]_{\text{eq}}$

$$x = [L] - [L]_{\text{eq}}$$

It is possible to derive that x evolves with time according to the following equation:

$$x = x(0) \times e^{-(k_1 + k_2)t},$$

where $x(0)$ is the deviation from equilibrium at $t = 0 \text{ h}$.

2.7 Let us boil 1.00 mol dm^{-3} L-isoleucine solution for 1 943 hours at 374 K. The rate constant for the forward reaction is $k_1(374 \text{ K}) = 9.02 \times 10^{-5} \text{ h}^{-1}$, K_{ep} for L-isoleucine epimerization has the



value of 1.38 (at 374 K). In the following calculation, shorten the concentration of L-isoleucine to [L] and of D-*allo*-isoleucine to [D]. Evaluate (with three significant figures) a) $[L]_{\text{eq}}$, b) diastereomeric excess (*de*) after boiling.

a) Calculation:

From the definition and mass balance we know that

$$x = [L] - [L]_{\text{eq}} = [D]_{\text{eq}} - [D]$$

We can derive the formulae for $[L]_{\text{eq}}$ (and also for $[D]_{\text{eq}}$) in terms of $[L]_0$

$$[L]_0 = [L]_{\text{eq}} + [D]_{\text{eq}}$$

$$[D]_{\text{eq}} = [L]_0 - [L]_{\text{eq}}$$

We also know that

$$K_{\text{ep}} = \frac{k_1}{k_2} = \frac{[D]_{\text{eq}}}{[L]_{\text{eq}}}$$

from which

$$[D]_{\text{eq}} = \frac{k_1}{k_2} [L]_{\text{eq}}$$

The substitution for $[D]_{\text{eq}}$ in $[D]_{\text{eq}} = [L]_0 - [L]_{\text{eq}}$ yields

$$[L]_{\text{eq}} = \frac{k_2}{k_1 + k_2} [L]_0$$

The rate constant k_2 is calculated from the epimerization constant K_{ep} as

$$k_2 = \frac{k_1}{K_{\text{ep}}} = \frac{9.02 \times 10^{-5} \text{ h}^{-1}}{1.38} = 6.54 \times 10^{-5} \text{ h}^{-1}$$

After the substitution of the numerical values, we get (with three significant digits)

$$[L]_{\text{eq}} = \frac{6.54 \times 10^{-5} \text{ h}^{-1}}{9.02 \times 10^{-5} \text{ h}^{-1} + 6.54 \times 10^{-5} \text{ h}^{-1}} \times 1 \text{ mol dm}^{-3} = 0.420 \text{ mol dm}^{-3}$$

$[L]_{\text{eq}} =$ mol dm⁻³ (with three significant figures)

b) Calculation:

de is defined as

$$de = \frac{[L] - [D]}{[L] + [D]} \times 100(\%)$$

We can express *de* in terms of the equilibrium values as

$$de = \frac{[L]_{\text{eq}} + x - [D]_{\text{eq}} + x}{[L]_{\text{eq}} + x + [D]_{\text{eq}} - x} \times 100(\%) = \frac{[L]_{\text{eq}} - [D]_{\text{eq}} + 2x}{[L]_0} \times 100(\%)$$

We already have the formula for $[L]_{\text{eq}}$ from task a). $[D]_{\text{eq}}$ in terms of $[L]_0$ is then

$$[D]_{\text{eq}} = \frac{k_1}{k_2} [L]_{\text{eq}} = \frac{k_1}{k_1 + k_2} [L]_0$$



Finally, we need to evaluate x in terms of $[L]_0$. We know that $x(0) = [D]_{\text{eq}}$, so

$$x = [D]_{\text{eq}} \times e^{-t(k_1 + k_2)} = \frac{k_1}{k_1 + k_2} [L]_0 \times e^{-t(k_1 + k_2)}$$

We can now express de as

$$de = \frac{\frac{k_2}{k_1 + k_2} [L]_0 - \frac{k_1}{k_1 + k_2} [L]_0 + 2 \frac{k_1}{k_1 + k_2} [L]_0 e^{-t(k_1 + k_2)}}{[L]_0} \times 100(\%) = \frac{k_2 - k_1 + 2k_1 e^{-t(k_1 + k_2)}}{k_1 + k_2} \times 100(\%)$$

$$de = \frac{6.54 \times 10^{-5} - 9.02 \times 10^{-5} + 2 \times 9.02 \times 10^{-5} e^{-1.943(9.02 \times 10^{-5} + 6.54 \times 10^{-5})}}{9.02 \times 10^{-5} + 6.54 \times 10^{-5}} \times 100(\%) = 69.8\%$$

(with three significant digits)

$de =$ % (with three significant figures)

a)

1 point for the mass balance equation

2 points for the equation for the equilibrium constant in terms of the rate constants and concentrations

2 points for the derivation of the formula for $[L]_{\text{eq}}$ in terms of $[L]_0$

1 point for the numerical value of k_2

1 point for the numerical value of $[L]_{\text{eq}}$

No points are scored if the calculations are not provided.

b)

2 points for the correct equation for de in terms of the equilibrium values

2 points for the derivation of the formulae for $[D]_{\text{eq}}$ in terms of $[L]_0$

2 points for the derivation of the formula for x in terms of $[L]_0$

2 points for the correct equation for de in terms of $[L]_0$

2 points for the correct numerical value of de based on correct formula

Some steps in the derivation may be taken implicitly or simultaneously. As long as they are correct, full marks will be scored for each of the partial steps. If the numerical calculation of k_2 in point a) is incorrect but k_2 is correctly used in task b), full marks are scored in task b).

No points are scored if the calculations are not provided.

Amino acids with a single chiral centre undergo racemization, e.g. L-arginine racemizes:

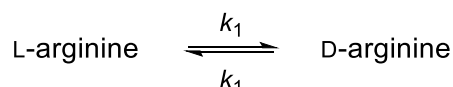

The time evolution of concentrations is governed by

$$\ln \frac{1 + \frac{[D]}{[L]}}{1 - \frac{[D]}{[L]}} = 2k_1 t + C$$

Here $[D]$ and $[L]$ are concentrations of D- and L-arginine at time t , k_1 is the rate constant, and the term C is set according to the initial concentrations.

Holy Roman Emperor Lothar III passed away during his journey to Sicily in 1137. To facilitate the repatriation of the remains, his body was, immediately after his death, boiled in water (373 K) for a certain time. Let us try to estimate the boiling time with the help of chemical kinetics. We know that



the rate constant k_1 of arginine racemization within the protein at 373 K and pH = 7 has the value of $5.10 \times 10^{-3} \text{ h}^{-1}$.

In order to analyse the isomeric composition of arginine in Lothar's bones, we need to start with transferring arginine into solution. Lothar's bones were hydrolyzed in a highly acidic environment for 4 hours at 383 K. The ratio of the optical isomers was $\frac{[D]}{[L]} = 0.090$. Lothar's wife Richenza was not boiled after her death. Her bones were hydrolyzed using the same procedure and in this case the ratio was $\frac{[D]}{[L]} = 0.059$. (Note that the racemization also takes place during the hydrolysis, with the rate constant k'_1 , different from k_1).

2.8 How long was the Holy Roman Emperor Lothar III boiled in water in 1137?

Note: The racemization of arginine is an extremely slow process at temperatures typically encountered in graves. As both bodies are only some 880 years old, we can neglect the natural racemization during this time.

Calculation:

Let us assume the following schemes for Lothar and Richenza



where 0 is the state before boiling with $\frac{[D]}{[L]}$ ratio X_0 , 1 corresponds to the Lothar's state after boiling in water in 1137 with the $\frac{[D]}{[L]}$ ratio X_1 , 2 is the Lothar's state after the acidic hydrolysis with the $\frac{[D]}{[L]}$ ratio X_2 , and 3 is the Richenza's state after the hydrolysis with the $\frac{[D]}{[L]}$ ratio X_3 . k_1 is the rate constant for racemization at 373 K, k'_1 is the rate constant for acid-catalyzed racemization at 383 K.

We can write the following equations:

$$\ln \frac{1 + X_3}{1 - X_3} = 2 k'_1 t_{\text{hydrolysis}} \quad (\text{eq. 1})$$

$$\ln \frac{1 + X_1}{1 - X_1} = 2 k_1 t_{\text{boiling}} \quad (\text{eq. 2})$$

$$\ln \frac{1 + X_2}{1 - X_2} = 2 k'_1 t_{\text{hydrolysis}} + \ln \frac{1 + X_1}{1 - X_1} \quad (\text{eq. 3})$$

Combining the equations leads to

$$\ln \frac{1 + X_2}{1 - X_2} = \ln \frac{1 + X_3}{1 - X_3} + 2 k_1 t_{\text{boiling}}$$

From which the time of boiling t_{boiling} is

$$\ln \frac{(1 + X_2)(1 - X_3)}{(1 - X_2)(1 + X_3)} = 2 k_1 t_{\text{boiling}}$$

Using the values $X_2 = 0.090$ and $X_3 = 0.059$ we get



$$t_{\text{boiling}} = \frac{1}{2 \times 5.10 \times 10^{-3}} \ln \frac{(1 + 0.090)(1 - 0.059)}{(1 - 0.090)(1 + 0.059)} = 6.11 \text{ h}$$

$t_{\text{boiling}} =$ **h**

8 points for rate equations describing the time evolution of the ratio between the optical isomers for Lothar and Richenza (2 points for each eq. 1 and 2; 4 points for eq. 3; 1 point for eq. 3 with an incorrect evaluation of C)

4 points for the combination of the equations to get the time of boiling

2 points for the evaluation of the boiling time

Some steps may be taken implicitly. If the correct boiling time is provided with correct assumptions in calculations, full marks will be scored.

Example of a partially correct solution:

1 point if the boiling time is derived correctly but the result is incorrect

No points are scored if the calculations are not provided.



Theoretical Problem 3 8% of the total	Question	3.1	3.2	3.3	3.4	3.5	3.6
	Points	2	6	7	3	7	8
	Score						
	Question	3.7	3.8	3.9	3.10	3.11	Total
	Points	6	10	5	2	6	62
	Score						

Problem 3. Emerging electro-mobility

Contemporary means of transportation rely on burning fossil fuels, although the efficiency of real combustion engines is inherently limited and typically ranges between 20 and 40%.

3.1 Mark the factors that can make the efficiency of a heat engine higher:

- Increasing the friction in the mechanical parts of the engine
- Increasing the burning temperature of the fuel in the engine
- Narrowing the working temperature interval of the engine
- Increasing the working pressure of the gas

2 points in total; 1 points for each correct answer (the second and fourth options in the list), - 1 points for each incorrect answer, total points scored in this question may not be negative

Fuel cells represent a way to improve the engine efficiency for future vehicles. The engine efficiency can be improved by using hydrogen-based fuel cells.

3.2 The standard enthalpy of formation of liquid water is $\Delta_f H^\circ(\text{H}_2\text{O}, \text{l}) = -285.84 \text{ kJ mol}^{-1}$, and the standard combustion enthalpy of isooctane is $\Delta_c H^\circ(\text{C}_8\text{H}_{18}, \text{l}) = -5\,065.08 \text{ kJ mol}^{-1}$ (both at 323.15 K). Calculate the values of specific (per unit of mass) combustion enthalpy at 232.15 K of pure liquid isooctane and pure gaseous hydrogen.

$$\Delta_c H_s^\circ(\text{C}_8\text{H}_{18}) =$$

$$\Delta_c H_s^\circ(\text{C}_8\text{H}_{18}) = \frac{\Delta_c H^\circ(\text{C}_8\text{H}_{18})}{M(\text{C}_8\text{H}_{18})} = \frac{-5\,065.08 \times 10^3 \text{ J mol}^{-1}}{114.23 \times 10^{-3} \text{ kg mol}^{-1}} = -44.34 \text{ MJ kg}^{-1}$$

$$\Delta_c H_s^\circ(\text{H}_2) =$$

$$\Delta_c H_s^\circ(\text{H}_2) = \frac{\Delta_c H^\circ(\text{H}_2)}{M(\text{H}_2)} = \frac{-285.84 \times 10^3 \text{ J mol}^{-1}}{2.02 \times 10^{-3} \text{ kg mol}^{-1}} = -141.50 \text{ MJ kg}^{-1}$$

6 points in total. Some of the steps may be condensed or performed implicitly. As long as this is performed correctly, full marks are scored for all of the elementary steps. Zero points will be scored for any numerical (sub)result given with wrong or missing units.

1 point for each numerically correct molar mass (including unit)

2 points for the correct way of calculation of the specific combustion enthalpy

1 point for each numerically correct specific combustion enthalpy (including unit)

-1 point for the wrong sign(s)



- 3.3 Calculate the standard electromotive force (EMF) of a fuel cell using gaseous oxygen and hydrogen, both ideal gases at 100 kPa and 323.15 K, to produce liquid water. Use the following entropy data for 323.15 K: $S^\circ(\text{H}_2\text{O},\text{l}) = 70 \text{ J K}^{-1} \text{ mol}^{-1}$, $S^\circ(\text{H}_2,\text{g}) = 131 \text{ J K}^{-1} \text{ mol}^{-1}$, $S^\circ(\text{O}_2,\text{g}) = 205 \text{ J K}^{-1} \text{ mol}^{-1}$.

Calculations:

The oxidation of molecular hydrogen requires the transfer of $z = 2$ electrons according to the equation: $\text{H}_2 + \frac{1}{2} \text{O}_2 \rightarrow \text{H}_2\text{O}$

$$\Delta_r S^\circ = S^\circ(\text{H}_2\text{O},\text{l}) - \left(S^\circ(\text{H}_2,\text{g}) + \frac{1}{2} S^\circ(\text{O}_2,\text{g}) \right) = -164 \text{ J K}^{-1} \text{ mol}^{-1}$$

$$\Delta_r G^\circ = \Delta_r H^\circ - T \Delta_r S^\circ =$$

$$= -285.84 \times 10^3 \text{ J mol}^{-1} + 323.15 \text{ K} \times 164 \text{ J K}^{-1} \text{ mol}^{-1} = -233 \text{ kJ mol}^{-1}$$

$$EMF = - \frac{\Delta_r G^\circ}{|z|F} = - \frac{-233 \times 10^3 \text{ J mol}^{-1}}{2 \times 96485 \text{ C mol}^{-1}} = 1.21 \text{ V}$$

EMF = V

7 points in total for the correct result calculated in any correct way. Some of the steps may be condensed or performed implicitly. As long as this is performed correctly, full marks are scored for all of the elementary steps. Zero points will be scored for any numerical (sub)result given with wrong or missing units.

1 point for the correct value of z resulting from the correctly written chemical equation

1 point for the correct formula for the reaction entropy according to the written chemical equation

1 point for the numerically correct value of the reaction entropy

1 point for the correct formula for the reaction Gibbs energy

1 point for the numerically correct value of the reaction Gibbs energy

1 point for the correct formula for the EMF

1 point for the numerically correct value of the EMF

-1 point for incorrect sign

- 3.4 Determine the ideal thermodynamic efficiency (η) of a fuel cell producing liquid water at 353.15 K. At this temperature, the enthalpy of formation of water is $\Delta_f H^\circ(\text{H}_2\text{O},\text{l}) = -281.64 \text{ kJ mol}^{-1}$ and the corresponding reaction Gibbs energy change is $\Delta_r G^\circ = -225.85 \text{ kJ mol}^{-1}$.

$$\eta = \frac{\Delta_r G^\circ}{\Delta_f H^\circ} = \frac{-225.85 \text{ kJ mol}^{-1}}{-281.64 \text{ kJ mol}^{-1}} \times 100\% = 80.19\%$$

$\eta =$ %

3 points in total

2 points for the correct way of calculation

1 point for the numerically correct result



- 3.5 A polymer membrane electrolyzer facility operates at the voltage of 2.00 V and is powered by a 10.0 MW wind turbine plant which was running at full power from 10 pm to 6 am. The electrolysis yielded 1 090 kg of pure hydrogen. Calculate the electrolysis yield defined as the mass of produced hydrogen divided by its theoretical produced mass.

Calculations:

Electric energy produced:

$$W = P \times \tau = 10 \times 10^6 \text{ W} \times 8 \times 3\,600 \text{ s} = 2.88 \times 10^{11} \text{ J}$$

is sufficient to transfer the charge:

$$Q = \frac{W}{U} = \frac{2.88 \times 10^{11} \text{ J}}{2 \text{ V}} = 1.44 \times 10^{11} \text{ C}$$

between the electrodes. Water formation is a two-electron process. Thus, the theoretical mass of hydrogen produced is:

$$m_{\text{theory}} = \frac{Q M}{|z| F} = \frac{1.44 \times 10^{11} \text{ C}}{2 \times 96\,485 \text{ C mol}^{-1}} \times 2.02 \times 10^{-3} \text{ kg mol}^{-1} = 1\,507 \text{ kg}$$

The efficiency of the electrolysis can be evaluated as the ratio:

$$\eta_{\text{electrolysis}} = \frac{m_{\text{real}}}{m_{\text{theory}}} \times 100\% = \frac{1\,090}{1\,507} \times 100\% = 72.3\%$$

$\eta_{\text{electrolysis}} =$ %

7 points in total for the numerically correct final result calculated in any correct way. Some of the steps may be condensed or performed implicitly. As long as this is performed correctly, full marks will be scored for all elementary steps. If only the final equation for m_{theory} is derived correctly, but its numerical value is wrong, 4 points will be scored for m_{theory} . If a wrong numerical subresult is used in subsequent steps which are performed correctly but yield a wrong numerical value, 4 points will be scored for m_{theory} . 0 points will be scored for any numerical (sub)result given with wrong or missing units.

1 point for the correct formula for W

1 point for the numerically correct value of W

1 point for the correct way of calculation of Q

1 point for the numerically correct value of Q

1 point for any correct way of calculation of the theoretical amount of hydrogen

1 point for the numerically correct theoretical amount of hydrogen

1 point for the numerically correct electrolysis efficiency

- 3.6 Calculate the mass of hydrogen required to drive the distance between Prague and Bratislava (330 km) at the average speed of 100 km h⁻¹ with a car fitted with a 310 kW electric engine running on average at a 15% rate of its maximum power. Assume that the efficiency of the hydrogen cell producing electrical energy is 75%, the efficiency of the electric engine is 95%, and the Gibbs energy change for combustion of hydrogen fuel is $\Delta_r G = -226 \text{ kJ mol}^{-1}$.



Calculations:

Driving time:

$$\tau = \frac{s}{v} = \frac{330 \text{ km}}{100 \text{ km h}^{-1} / 3600 \text{ s}} = 11\,880 \text{ s}$$

determines the ideal amount of energy required to cover the given distance:

$$W_{\text{ideal}} = P \times f \times \tau = 310 \times 10^3 \text{ W} \times 0.15 \times 11\,880 \text{ s} = 5.52 \times 10^8 \text{ J.}$$

Assuming the overall non-unity efficiency, the real energy required is:

$$W_{\text{real}} = \frac{W_{\text{ideal}}}{\eta_{\text{electrolysis}} \times \eta_{\text{engine}}} = \frac{5.52 \times 10^8 \text{ J}}{0.75 \times 0.95} = 7.75 \times 10^8 \text{ J.}$$

This can be combined with the standard Gibbs energy of liquid water formation to yield the amount of hydrogen:

$$m = \frac{W_{\text{real}}}{|\Delta_r G^\circ|} \times M = \frac{7.75 \times 10^8 \text{ J}}{2.26 \times 10^5 \text{ J mol}^{-1}} \times 2.02 \times 10^{-3} \text{ kg mol}^{-1} = 6.93 \text{ kg.}$$

$m =$ kg

8 points in total for the numerically correct final result calculated in any correct way. Some of the steps may be condensed or performed implicitly. As long as this is performed correctly, full marks will be scored for all of the elementary steps. If only the final relation for m is derived correctly, but its numerical value is wrong, 6 points will be scored in total. If a wrong numerical subresult is used in subsequent steps which are performed correctly but yield a wrong numerical value, 6 points will be scored for m_{theory} . 0 points will be scored for any numerical (sub)result given with wrong or missing units.

1 point for the correct formula for τ

1 point for the correct value of τ

1 point for the correct formula for W_{ideal}

1 point for the numerically correct value of W_{ideal}

1 point for the correct formula for W_{real}

1 point for the numerically correct value of W_{real}

1 point for the correct formula for m

1 point for the numerically correct value of m

The low efficiency of hydrogen production and the safety issues connected with its storage impede spreading the hydrogen-based transportation technology. Hydrazine (N_2H_4) fuel cells might be a suitable alternative.

The following standard reduction potentials for aqueous hydrazine systems are available:

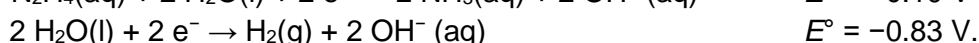
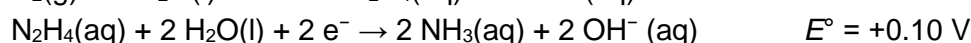
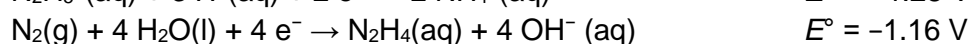
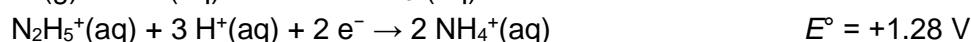
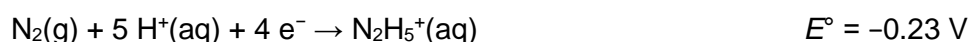



3.7 Fill in the following Latimer diagrams with the forms of hydrazine and ammonia prevailing at the given conditions and write the redox potential value for each arrow representing the electrochemical half-reaction. Record all the necessary calculations.

a) Acidic environment (pH = 0)

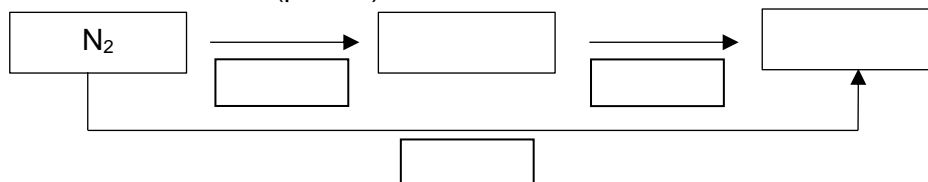

b) Basic environment (pH = 14)

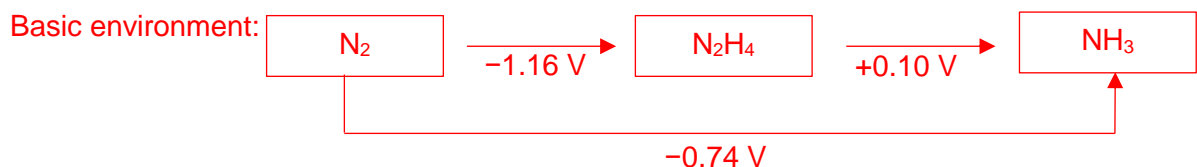
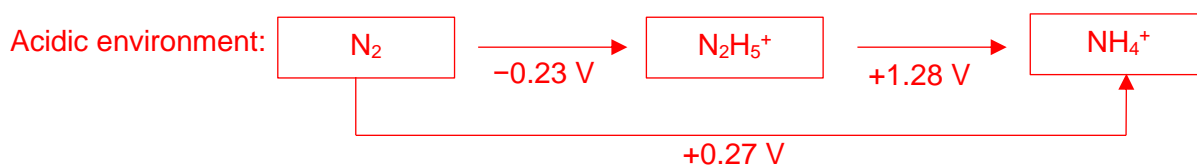
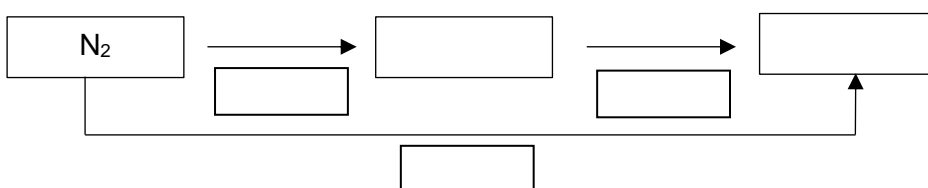

Calculations:

Redox potentials for N_2 to NH_4^+ and N_2 to NH_3 , respectively, are calculated as follows:

$$E^\circ(\text{N}_2/\text{NH}_4^+) = \frac{4 E^\circ(\text{N}_2/\text{N}_2\text{H}_5^+) + 2 E^\circ(\text{N}_2\text{H}_5^+/\text{NH}_4^+)}{6} = \frac{4 \times (-0.23) + 2 \times 1.28}{6} \text{ V} = 0.27 \text{ V}$$

$$E^\circ(\text{N}_2/\text{NH}_3) = \frac{4 E^\circ(\text{N}_2/\text{N}_2\text{H}_4) + 2 E^\circ(\text{N}_2\text{H}_4/\text{NH}_3)}{6} = \frac{4 \times (-1.16) + 2 \times 0.10}{6} \text{ V} = -0.74 \text{ V}$$

6 points in total

1 point for each diagram completely correctly filled with chemical species, no partial points given if any mistake occurs

1 point for the numerically correct value of each of the standard redox potentials $E^\circ(\text{N}_2/\text{NH}_4^+)$ and $E^\circ(\text{N}_2/\text{NH}_3)$, no partial points given if any mistake occurs

1 point for each diagram correctly filled with the remaining standard redox potentials, no partial points given if any mistake occurs



Due to the toxicity, odour and its environmental impact, it is extremely unfavourable to produce ammonia in fuel cells.

- 3.8 Write down the net reaction for the decomposition of hydrazine under basic conditions to (i) ammonia and nitrogen and (ii) nitrogen and hydrogen and calculate the corresponding equilibrium constants at $T = 298.15 \text{ K}$.

Equations for hydrazine decomposition:

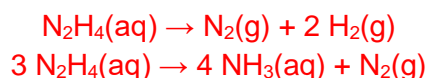

Calculations:

$$\Delta_r G^\circ = -RT \ln K = -|z|FE^\circ \rightarrow K = \exp\left(\frac{|z|FE^\circ}{RT}\right)$$

Hydrazine decomposition to NH_3 and N_2 in a basic environment:

$$E^\circ = E^\circ(\text{N}_2\text{H}_4/\text{NH}_3) + (-E^\circ(\text{N}_2/\text{N}_2\text{H}_4)) = (0.10 + 1.16) \text{ V} = 1.26 \text{ V}$$

$$K = \exp\left(\frac{|z|FE^\circ}{RT}\right) = \exp\left(\frac{4 \times 96\,485 \text{ C mol}^{-1} \times 1.26 \text{ V}}{8.314 \text{ J K}^{-1} \text{ mol}^{-1} \times 298.15 \text{ K}}\right) = 1.6 \times 10^{85}$$

$K =$

Hydrazine decomposition to H_2 and N_2 in a basic environment:

$$E^\circ = E^\circ(\text{H}_2\text{O}/\text{H}_2) + (-E^\circ(\text{N}_2/\text{N}_2\text{H}_4)) = (-0.83 + 1.16) \text{ V} = 0.33 \text{ V}$$

$$K = \exp\left(\frac{|z|FE^\circ}{RT}\right) = \exp\left(\frac{4 \times 96\,485 \text{ C mol}^{-1} \times 0.33 \text{ V}}{8.314 \text{ J K}^{-1} \text{ mol}^{-1} \times 298.15 \text{ K}}\right) = 2.1 \times 10^{22}$$

$K =$

10 points in total

2 points for each correctly balanced reaction (4 points in subtotal)

4 points for the correct way of calculation of the equilibrium constant (2 points will be scored if the correct formula for the related standard reaction Gibbs energy is given)

1 point for each numerically correct value of equilibrium constant (2 points in subtotal), no points will be scored if a wrong value of z is used in the calculation

Rechargeable lithium-based batteries are an alternative to fuel cells. Lithium-ion batteries commonly use graphite for one of the electrodes, in which lithium clusters intercalate in between the graphite sheets. The other electrode is made of lithium cobalt oxide, which can reversibly absorb lithium ions moving from one electrode to the other during the charge and discharge processes. The half-reactions relevant for the system can be formally written as:

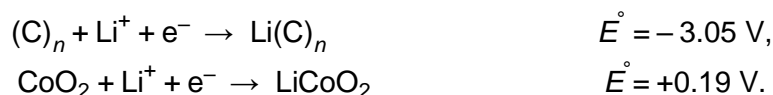

- 3.9 Using the formalism given above, write down the overall chemical reaction occurring in the battery during the **discharge** process. Give the oxidation states of the cobalt atom.



Because $E_{\text{lower}}^{\circ} > E_{\text{upper}}^{\circ}$, the upper reaction occurs spontaneously in the opposite direction. Therefore, the discharge of the battery occurs when lithium leaves the graphite structure and its ions intercalate in the cobalt oxide:



5 points in total

1 point for each oxidation state of cobalt atom

3 points for the overall reaction

No points will be scored for the reaction written in the opposite direction.

- 3.10 Tick the boxes to get the correct statements which are valid for the **discharge** of the lithium-based battery described in 3.9:

Li(C) _n electrode is	<input type="checkbox"/>	cathode	<input type="checkbox"/>	because lithium ions are reduced here.
	<input checked="" type="checkbox"/>	anode	<input checked="" type="checkbox"/>	because lithium atoms are oxidized here.
LiCoO ₂ electrode is	<input checked="" type="checkbox"/>	cathode	<input checked="" type="checkbox"/>	because cobalt ions are reduced here.
	<input type="checkbox"/>	anode	<input type="checkbox"/>	because cobalt ions are oxidized here.

2 points in total

1 point for each correct pair of boxes marked

- 3.11 Assume that a C₆ unit, a CoO₂ unit and Li atom form the active battery mass required to transfer one electron between the electrodes. Using the corresponding standard EMF, calculate the theoretical specific reversible charge capacity (in mAh g⁻¹) and the energy density (in kWh kg⁻¹) of such a model lithium ion battery related to the whole active battery mass.

Calculations:

The transfer of 1 mol of electrons requires at least the molar mass of the active ingredients $M_{\text{total}} = 169.94 \text{ g mol}^{-1}$, meaning that the specific charge capacity is:

$$c_{q,s} = \frac{F}{M} = \frac{96\,485 \text{ C mol}^{-1}}{169.94 \text{ g mol}^{-1}} = 567.76 \text{ C g}^{-1} \approx 567.76 \text{ A s g}^{-1} \approx 157.71 \text{ mAh g}^{-1}$$

Charge capacity ($c_{q,s}$) = mAh g⁻¹

Calculations:

Assuming the standard EMF (voltage) of the battery is:

$$U = E^{\circ}(\text{Li}_{x_1}\text{CoO}_2/\text{Li}_{x_2}\text{CoO}_2) - E^{\circ}(\text{Li}^+/\text{Li}^0) = 0.19 + 3.05 \text{ V} = 3.24 \text{ V},$$

the energy density of the battery can be calculated as:

$$\rho_{el} = U \times c_{q,s} = 3.24 \text{ V} \times 567.76 \text{ C g}^{-1} = 1\,839.6 \text{ W s g}^{-1} \approx 0.511 \text{ kWh kg}^{-1}$$

Energy density (ρ_{el}) = kWh kg⁻¹



6 points in total for the numerically correct final result. Some of the steps may be condensed or performed implicitly. As long as this is performed correctly, full marks will be scored for all elementary steps.

1 point will be scored if only the correct numerical value for the Gibbs energy associated with the electron transfer is given. Zero points will be scored for any numerical (sub)result given with wrong or missing units.

1 point for the numerically correct value of the active molar mass

1 point for the correct formula for the specific charge capacity

1 point for the numerically correct value of the specific charge capacity

1 point for the numerically correct value of EMF

1 point for the correct formula for the energy density

1 point for the numerically correct value of the energy density



Theoretical Problem 4	Question	4.1	4.2	4.3	4.4	4.5	4.6	4.7	4.8	Total
	6% of the total	Points	2	5	1	2	7	2	3	2
	Score									

Problem 4. Column chromatography of radioactive copper

^{64}Cu for positron emission tomography is prepared by the bombardment of a zinc target with deuterium nuclei (further referred to as the activated target).

- 4.1 Write down the balanced equation for the ^{64}Zn nucleus bombardment with deuterium nuclei, giving ^{64}Cu . Specify the corresponding atomic and mass numbers of all species. Disregard the charges.

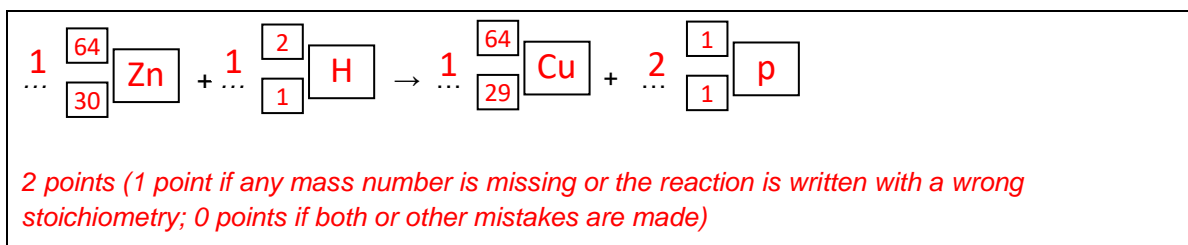

The activated target is dissolved in concentrated hydrochloric acid (HCl (aq)) to give a mixture containing Cu^{2+} and Zn^{2+} ions and their respective chlorido complexes.

- 4.2 Calculate the mole fraction of negatively charged copper species with respect to the amount of copper prepared by zinc target activation. Assume $[\text{Cl}^-] = 4 \text{ mol dm}^{-3}$. For the overall complexation constants, β , see Table 1.

Before you start the calculation, write down the charges in the upper right boxes:

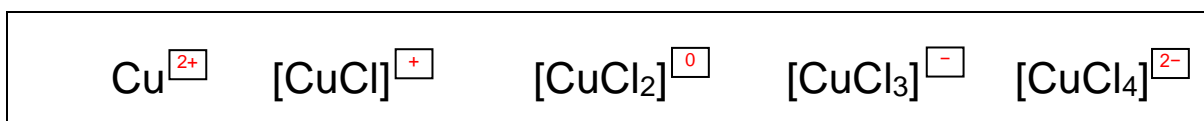

1 point for correct charges for all species; 0 points for 1 or more incorrect charge(s)

Table 1. Overall complexation constants β of Cu species (charges were omitted in the formula).

$$\beta_i = \frac{[\text{CuCl}_i]}{[\text{Cu}] \times [\text{Cl}]^i}$$

	i in $[\text{CuCl}_i]$			
	1	2	3	4
β_i	2.36	1.49	0.690	0.055



Calculation:

The mole fraction is the sum of the distribution coefficients of $[\text{CuCl}_3]^-$ and $[\text{CuCl}_4]^{2-}$:

$$\begin{aligned} \frac{([\text{CuCl}_3]^-) + ([\text{CuCl}_4]^{2-})}{c(\text{Cu}^{2+})} &= \frac{(\beta_3 [\text{Cl}^-]^3 + \beta_4 [\text{Cl}^-]^4)}{(1 + \beta_1 [\text{Cl}^-] + \beta_2 [\text{Cl}^-]^2 + \beta_3 [\text{Cl}^-]^3 + \beta_4 [\text{Cl}^-]^4)} \\ &= \frac{(0.69 \times 4^3 + 0.055 \times 4^4)}{(1 + 2.36 \times 4 + 1.49 \times 4^2 + 0.69 \times 4^3 + 0.055 \times 4^4)} = \\ &= 58.24 / 92.52 = 0.63 \end{aligned}$$

Mole fraction: 0.63

(answer with 2 digits after decimal point)

4 points for completely correct answer; -1 point for the wrong mole fraction obtained by the correct procedure

The mixture containing Cu^{2+} and Zn^{2+} ions and their respective chlorido complexes was separated with an anion exchange resin. Dry resin in OH^- form was dispersed in water and the suspension was transferred into a column. To occupy all sites with Cl^- ions (i.e. to obtain resin in a Cl^- form), the resin was washed with hydrochloric acid and then with deionized water to wash out all the unbound Cl^- ions.

4.3 Everything was initially at laboratory temperature before washing with hydrochloric acid. Does the column temperature change during the washing with hydrochloric acid?

- No.
- Yes, the temperature decreases.
- Yes, the temperature increases.

1 point for the correct answer

The mixture containing Cu^{2+} and Zn^{2+} ions and their respective chlorido complexes was transferred onto the resin-filled column. Hydrochloric acid solution was used as an eluent.

Using the simple experimental formula below, you can calculate quantities that determine average elution properties of both copper species and zinc species on the column.

The retention volume V_R (the mobile phase volume at which 50% of the compound has been eluted from the column) can be calculated as follows:

$$V_R = D_g \times m_{\text{resin,dry,OH form}} + V_0$$

4.4 Using the average mass distribution coefficients D_g ($D_g(\text{Cu species}) = 17.4 \text{ cm}^3 \text{ g}^{-1}$, $D_g(\text{Zn species}) = 78.5 \text{ cm}^3 \text{ g}^{-1}$), calculate the retention volumes V_R in cm^3 of both copper species and zinc species. The mass of dry resin in OH^- form $m_{\text{resin,dry,OH form}} = 3.72 \text{ g}$ and the void volume of a column $V_0 = 4.93 \text{ cm}^3$.



Calculation:

$$V_R(\text{Cu species}) = 69.7 \text{ cm}^3 \text{ (answer with 1 digit after the decimal)}$$

$$V_R(\text{Zn species}) = 297 \text{ cm}^3 \text{ (answer with 0 digit after the decimal)}$$

2 points in total (1 point for each V_R)

If you cannot find the answer, use $V_R(\text{Cu species}) = 49.9 \text{ cm}^3$ and $V_R(\text{Zn species}) = 324 \text{ cm}^3$ for further calculations.

Using the simple experimental formula, separation of two sets of species, **A** and **B**, can be considered complete if

$$V_{0.001}(\mathbf{A}) - V_{0.999}(\mathbf{B}) > 10V_c$$

where $V_{0.001}$ is the mobile phase volume at which 0.1% of **A** has been eluted from the column, and $V_{0.999}$ is the mobile phase volume at which 99.9% of **B** has been eluted from the column.

$$V_{0.001}(\mathbf{A}) = V_R(\mathbf{A}) \times \left(1 - 6.91 \sqrt{d_p/L_c}\right)$$

$$V_{0.001}(\mathbf{B}) = V_R(\mathbf{B}) \times \left(1 - 6.91 \sqrt{d_p/L_c}\right)$$

$$V_{0.999}(\mathbf{B}) = 2V_R(\mathbf{B}) - V_{0.001}(\mathbf{B})$$

- 4.5 Based on a calculation, decide whether copper species were separated completely from zinc species. The volume of the column filled with the swollen resin $V_c = 10.21 \text{ cm}^3$, the resin particle diameter $d_p = 0.125 \text{ mm}$, and the height of the wet resin in a swollen state in the column $L_c = 13.0 \text{ cm}$.

According to the retention volumes (V_R), $V_{0.001}(\mathbf{A})$ corresponds to $V_{0.001}(\text{Zn species})$ and $V_{0.999}(\mathbf{B})$ corresponds to $V_{0.999}(\text{Cu species})$

$$V_{0.001}(\mathbf{A}) = 297 \text{ cm}^3 \times \left(1 - 6.91 \times \sqrt{0.125 \text{ mm}/130 \text{ mm}}\right) = 233 \text{ cm}^3$$

2 points (1 point if L_c and d_p are used with different units;)

$$V_{0.999}(\mathbf{B}) = 2 \times 69.7 \text{ cm}^3 - 54.8 \text{ cm}^3 = 84.6 \text{ cm}^3$$

1 point (even with the wrong V_R and $V_{0.001}$ for Cu species)

$$\text{where } V_{0.001}(\text{Cu species}) = 69.7 \text{ cm}^3 \times \left(1 - 6.91 \times \sqrt{0.125 \text{ mm}/130 \text{ mm}}\right) = 54.8 \text{ cm}^3$$

2 points (1 point if L_c and d_p are used with different units)

It is possible to separate copper species from zinc species.

True False

2 points for the correct decisions based on $V_{0.001}$ and $V_{0.999}$ calculations



- 4.6 Calculate the theoretical value of the total ion exchange mass capacity of the dry resin used in this problem, $Q_{m,theor}$, in mmol g^{-1} . Consider tetraalkylammonium groups were the only ones responsible for ion exchange of the resin. No other nitrogen containing groups were present. The mass fraction of nitrogen in the dry resin was 4.83%.

$$Q_{m,theor} = w(\text{N}) / M(\text{N}) = 0.0483 / (14.01 \text{ g mol}^{-1}) = 3.45 \text{ mmol g}^{-1}$$

2 points (1 point if the value is in the wrong order of magnitude)

(answer with 2 digits after decimal point)

If you cannot find the answer, use $Q_{m,theor} = 4.83 \text{ mmol g}^{-1}$ for further calculations.

In reality, not all tetraalkylammonium groups are involved in the ion exchange. To determine the total ion exchange volume capacity, Q_v , the column filled with 3.72 g dry resin converted to the Cl^- form was washed with the excess of sodium sulfate solution. The effluent was collected in a 500 cm^3 volumetric flask, which was then filled with water to the mark. An aliquot of 100 cm^3 was potentiometrically titrated with $0.1027 \text{ mol dm}^{-3}$ silver nitrate. The silver nitrate solution volume at the equivalence point was 22.20 cm^3 . The volume of the column filled with the swollen resin, V_c , was 10.21 cm^3 .

- 4.7 Calculate the Q_v of the swollen resin in mmol of active tetraalkylammonium groups per cm^3 of the swollen resin.

$$Q_v = V(\text{AgNO}_3) \times c(\text{AgNO}_3) \times V_{\text{flask}} / (V_{\text{aliquot}} \times V_c) =$$

$$= 0.0222 \text{ dm}^3 \times 0.1027 \text{ mol dm}^{-3} \times 0.500 \text{ dm}^3 / (0.100 \text{ dm}^3 \times 0.01021 \text{ dm}^3) = 1.12 \text{ mmol cm}^{-3}$$

3 points

-1 point if dilution is forgotten

-1 point for the wrong order of magnitude

(1 point for titration calculation)

(answer with 2 digits after decimal point)

If you cannot find the answer, use $Q_v = 1.00 \text{ mmol cm}^{-3}$ for further calculations.

- 4.8 Calculate the mole fraction (x) of the tetraalkylammonium groups actively involved in the ion exchange.

$$x = Q_v \times V_c / (Q_{m,theor} \times m_{\text{resin}}) = 1.12 \text{ mmol cm}^{-3} \times 10.21 \text{ cm}^3 / (3.45 \text{ mmol g}^{-1} \times 3.72 \text{ g}) =$$

$$0.891$$

2 points

(answer with 3 digits after decimal point)



Theoretical Problem 5	Question	5.1	5.2	5.3	5.4	5.5	5.6	5.7	5.8	5.9
	Points	3	3	1	5	3	2	4	1	2
	Score									
8% of the total	Question	5.10	5.11	5.12	5.13	5.14	5.15	5.16	5.17	Total
	Points	5	7	3	2	6	1	1	1	50
	Score									

Problem 5. Bohemian garnet

Bohemian garnet (pyrope) is a famous Czech blood coloured semi-precious stone. The chemical composition of natural garnets is expressed by the general stoichiometric formula of $A_3B_2(SiO_4)_3$, where A^{II} is a divalent cation and B^{III} is a trivalent cation. Garnets have a cubic unit cell that contains 8 formula units. The structure comprises 3 types of polyhedra: the A^{II} cation occupies a dodecahedral position (it is surrounded with eight O atoms), the B^{III} cation occupies an octahedral position (it is surrounded with six O atoms) and Si^{IV} is surrounded with four O atoms arranged into a tetrahedron.

The most common garnet mineral is almandine with the formula of $Fe_3Al_2(SiO_4)_3$. Its unit cell parameter is $a = 11.50 \text{ \AA}$.

5.1 Calculate the theoretical density of almandine.

$$M(\text{almandine}) = 497.75 \text{ g mol}^{-1}$$

$$\rho = m / V = (8 \times M) / (N_A \times a^3) = (8 \times 497.75) / [6.022 \times 10^{23} \times (11.50 \times 10^{-8})^3] = 4.35 \text{ g cm}^{-3}$$

3 points in total

correct molar mass 1 point, correct equation 1 point, correct numerical calculation starting from correct equation 1 point

The Bohemian garnet has the composition of $Mg_3Al_2(SiO_4)_3$. Pure compound is colourless and the colour of natural garnets comes from chromophores – transition metal cations that substitute the host material cations. The red colour of the Bohemian garnet comes from trace amounts of Cr^{III} ions in the octahedral sites and Fe^{II} ions in the dodecahedral sites.

5.2 Draw the splitting diagram for the $[Cr^{III}O_6]^{oct}$ d-orbitals and fill it with electrons.

Splitting diagram – configuration d^3 :

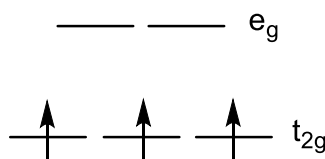

3 points in total

correct orbital splitting 1 point, correct number of electrons 1 point, correct configuration according



to Hund's rule 1 point, -1 point if only a line not indicating the electron spin is used (deducted only once per Problem); orbital marking is not evaluated

- 5.3 Identify the 1st transition row element(s) whose trivalent cation(s) M^{III} placed in an **octahedral** position is/are diamagnetic in the low-spin arrangement and paramagnetic in the high-spin arrangement.

Co

1 point

correct answer 1 point, incorrect answer -1 point, minimum 0 points (the score may not be negative)

- 5.4 The figure below shows d-orbitals splitting in the dodecahedral crystal field. Fill in the electrons for the [Fe^{II}O₈]^{dod} chromophore for both existing arrangements.

a) high-spin arrangement b) low-spin arrangement

5 points in total
correct number of electrons 1 point, correct high-spin configuration 2 points, correct low-spin configuration 2 points (any other configuration 0 points: high spin and low spin configurations differ in total spin. Any other configurations do not fulfil this condition.)
If incorrect number of electrons is considered, then the correctness of such a configuration is taken into account.

- 5.5 Derive the inequalities (e.g. $P < E_1 + E_2 + E_3$) for the pairing energy (P) magnitude in relation to energies E_1 , E_2 and E_3 for both arrangements.

a) high-spin arrangement: $P > E_1 - E_3$

b) low-spin arrangement: $P < E_1 - E_3$

3 points in total

correct BOTH inequality signs 1 point (half-points are not allowed), correct right-side terms (according to the answer in 5.4) 1 + 1 points

- 5.6 Assuming that $P > E_3$, identify the 1st transition row element(s) whose divalent cation M^{II} placed in dodecahedral position is diamagnetic in the low-spin arrangement and paramagnetic in the high-spin arrangement.



Cr, Ni

2 points

each correct metal 1 point, each incorrect metal – 1 point, minimum 0 points (the score may not be negative)

The figures below show simplified absorption spectra of four coloured minerals – blood-coloured Bohemian garnet, green uvarovite, blue sapphire and yellow-orange citrine.

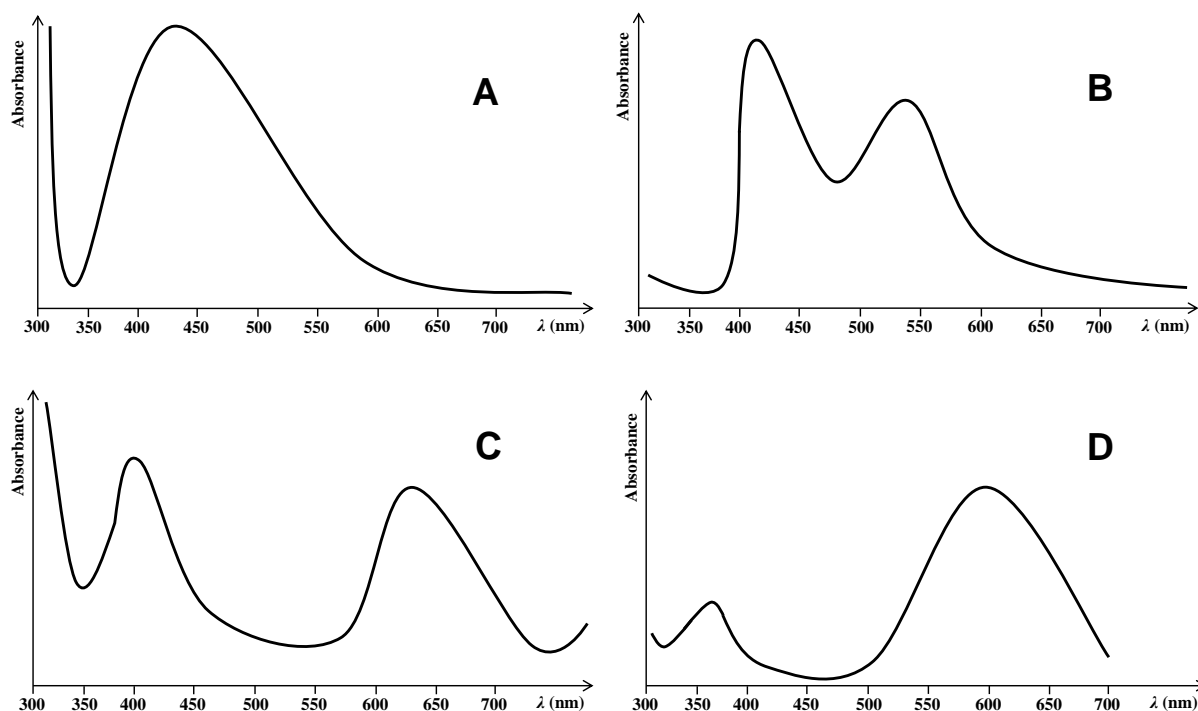

5.7 Match the spectra with the minerals.

Bohemian garnet: **B**

Sapphire: **D**

Uvarovite: **C**

Citrine: **A**

4 points in total, each correct assignment 1 point

5.8 If illuminated with monochromatic blue-green light, how will the Bohemian garnet look?

Red

Blue

Yellow-orange

Black

Yellow

Blue-green

Violet

White

1 point



Andradite is another garnet mineral; its chemical composition is $\text{Ca}_3\text{Fe}_2(\text{SiO}_4)_3$. A double cation substitution – Ti^{IV} for Fe^{III} in the octahedral position and Fe^{III} for Si^{IV} in the tetrahedral position – gives rise to black schorlomite. Its chemical composition can be expressed as $\text{Ca}_3[\text{Fe},\text{Ti}]_2^{\text{OCT}}([\text{Si},\text{Fe}]^{\text{TET}}\text{O}_4)_3$.

- 5.9 Calculate the percentage of Si^{IV} ions in a sample of schorlomite that must be substituted with Fe^{III} , if we know that 5% of Fe^{III} ions in octahedral position are substituted with Ti^{IV} .

Both substitutions change the charge by 1 unit per ion. Taking total number of ions in formula into consideration we get:

$$5\% \times 2 = p \times 3$$

$$p = 3.33\%$$

2 points

correct starting consideration in the form of an equation 1 point, correct numerical calculation 1 point

The colour of the mineral is caused by two chromophores: $[\text{Fe}^{\text{III}}\text{O}_6]^{\text{OCT}}$ and $[\text{Fe}^{\text{III}}\text{O}_4]^{\text{TET}}$. The central ions of both chromophores have equal number of unpaired electrons.

- 5.10 Draw the d-orbitals splitting diagrams for both chromophores and fill in the electrons.

$[\text{Fe}^{\text{III}}\text{O}_6]^{\text{OCT}}$:

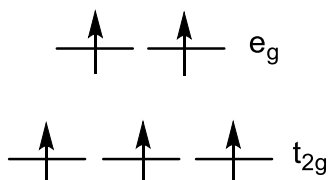

$[\text{Fe}^{\text{III}}\text{O}_4]^{\text{TET}}$:

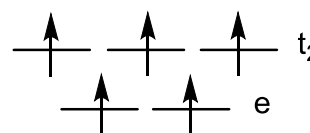

5 points in total

correct octahedral splitting 1 point, correct tetrahedral splitting 1 point, correct number of electrons 1 point, correct high-spin configurations 1 + 1 points; orbital marking is not evaluated.

Tetrahedral field causes a smaller splitting than the octahedral field ($\Delta_{\text{tet}} = \frac{4}{9} \Delta_{\text{OCT}}$). Surprisingly for the Fe^{III} ion, the energy of the first d–d transition (although very weak) for the octahedral chromophore is smaller ($11\,000\text{ cm}^{-1}$) than for the tetrahedral one ($22\,000\text{ cm}^{-1}$).

- 5.11 Calculate the size of pairing energy (P) and the sizes of Δ_{OCT} and Δ_{TET} splitting. Assume that the pairing energy is equal in both chromophores.

Because $\Delta_{\text{OCT}} < P$ (high-spin configuration in tetrahedral as well as in octahedral field), the wavenumber corresponds to electron transition from the upper to the lower level in both cases and thus:

$$11\,000\text{ cm}^{-1} = P - \Delta_{\text{OCT}}$$



$$22\,000\text{ cm}^{-1} = P - \Delta_{\text{tet}} = P - \frac{4}{9} \Delta_{\text{oct}}$$

By solving the system of these equations we get:

$$P = 30\,800\text{ cm}^{-1}$$

$$\Delta_{\text{oct}} = 19\,800\text{ cm}^{-1}$$

$$\Delta_{\text{tet}} = 8\,800\text{ cm}^{-1}$$

Alternative solution comes from the assumption (independent of the result of 5.10) of the low-spin arrangement in octahedral field and high-spin arrangement in tetrahedral field:

$$11\,000\text{ cm}^{-1} = \Delta_{\text{oct}} - P$$

$$22\,000\text{ cm}^{-1} = P - \Delta_{\text{tet}} = P - \frac{4}{9} \Delta_{\text{oct}}$$

By solving the system of these equations we get:

$$P = 48\,400\text{ cm}^{-1}$$

$$\Delta_{\text{oct}} = 59\,400\text{ cm}^{-1}$$

$$\Delta_{\text{tet}} = 26\,400\text{ cm}^{-1}$$

7 points in total

formulation of equations 2 + 2 points, correct energy values (i.e. correct numerical calculation starting from correct assumption) 1 + 1 + 1 points

Synthetic garnet YAG (Yttrium Aluminium Garnet), used in optoelectronics, has the composition of $\text{Y}_3\text{Al}_5\text{O}_{12}$. Its structure is derived from the general garnet structure $\text{A}_3\text{B}_2(\text{SiO}_4)_3$ by placing the ions Y^{III} and Al^{III} to the A, B and Si positions.

5.12 Based on your knowledge of the relative ion radii, determine which cation occupies which position.

A: Y^{III} B: Al^{III} Si: Al^{III}

3 points in total, each correct assignment 1 point

5.13 For the use in LED technology, YAG is doped with Ce^{III} . Determine the values of x and y in the formula of YAG in which 5% of yttrium atoms are substituted with cerium.

$\text{Y}_x\text{Ce}_y\text{Al}_5\text{O}_{12}$ $x = 2.85$ $y = 0.15$

2 points in total, each value 1 point

If you don't get result, use $x = 2.25$ and $y = 0.75$.



- 5.14 The Ce^{III}-doped YAG is prepared by annealing the mixture of Y₂O₃, Al₂O₃ and CeO₂ in H₂ atmosphere. Use the formula from 5.13, write down a balanced equation for this reaction with the smallest whole-number stoichiometric coefficients.

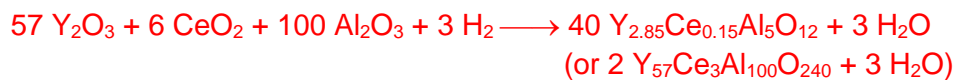

for $x = 2.25$ and $y = 0.75$:

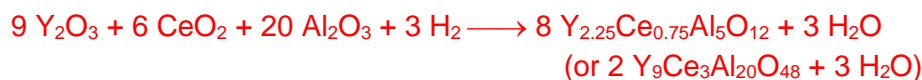

complete set of correct coefficients 6 points

-1 point if correct stoichiometric coefficients are only on one side of the equation

-1 point if stoichiometric coefficients are correct and whole-number but not the smallest

-2 points if stoichiometric coefficients are correct but not whole-numbers

if hydrogen+water are omitted from the equation or when redox change was incorrect, then penalty

-3 point is applied

if incorrect formula in 5.13 is given, the answer is judged with respect to the incorrect formula

Doping the YAG structure with rare-earths ions enables the production of lasers with emission wavelengths ranging from the UV to the mid-IR region. In the scheme below, simplified f-f energy transitions of selected rare-earths ions are shown.

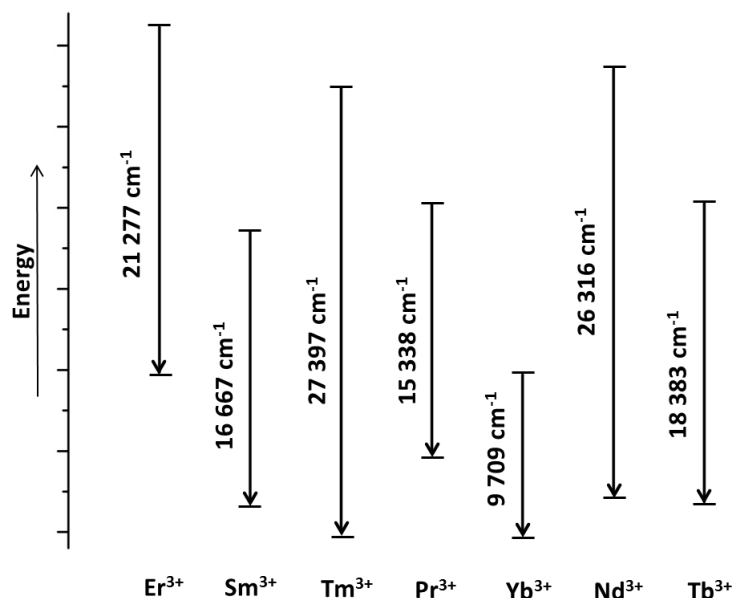

- 5.15 Which cation has a transition which corresponds to blue light emission.

Er³⁺

Sm³⁺

Tm³⁺

Pr³⁺

Yb³⁺

Nd³⁺

Tb³⁺

1 point



5.16 Calculate the emission wavelength of this light.

$$\lambda = \frac{1}{2\,127\,700} \text{ m} = 4.70 \times 10^{-7} \text{ m} = 470 \text{ nm}$$

1 point. The result of 5.16 is evaluated with respect to the answer in 5.15

5.17 According to a legend, Noah used a stick with a garnet stone for illumination during his voyage. Assuming only the photoluminescence effect, determine the colour of the laser light emitted from his stick if the stone were the blood-coloured Bohemian garnet.

- | | | | |
|---------------------------------|------------------------------------------------|----------------------------------------|--------------------------------|
| <input type="checkbox"/> Red | <input type="checkbox"/> Blue | <input type="checkbox"/> Yellow-orange | <input type="checkbox"/> Black |
| <input type="checkbox"/> Yellow | <input checked="" type="checkbox"/> Blue-green | <input type="checkbox"/> Violet | <input type="checkbox"/> White |

1 point



Theoretical Problem 6 7% of the total	Question	6.1	6.2	6.3	6.4	6.5	6.6	6.7	6.8	Total
	Points	18	4	8	3	4	12	16	3	68
	Score									

Problem 6. Let's go mushrooming

Mushrooming belongs to Czech and Slovak traditional pastimes. While some of our mushroom species are edible, some are inedible or even poisonous.

Inky cap (*Coprinopsis atramentaria*) is considered edible and delicious. It contains a natural compound called coprine (**E**), which can be easily synthesized from ethyl 3-chloropropanoate (**1**).

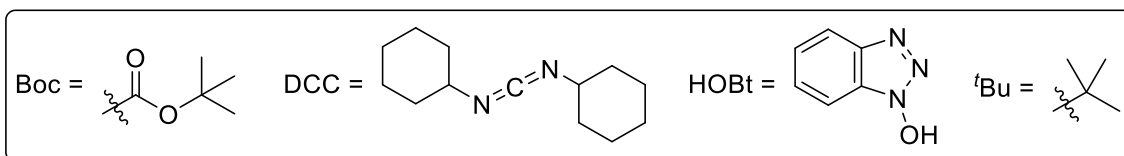
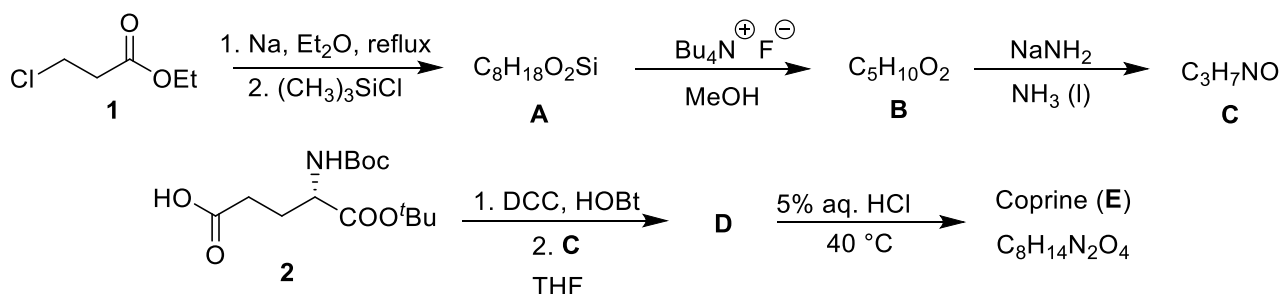

- 6.1 Draw the formulae of compounds **A–E** including stereochemistry when necessary. *Hint: The first reaction affording compound **A** proceeds via an organometallic compound which then cyclizes.*

<p>A</p> <p>4 points</p>	<p>B</p> <p>2 points for TMS deprotection</p>	<p>C</p> <p>4 points for ethoxy group substitution by amino group</p>
<p>D</p> <p>4 points for amide formation 2 points for the corresponding ester formation -2 points for wrong or undefined stereo-chemistry (2 rules may apply at once)</p>		<p>E</p> <p>4 points for Boc and ^tBu deprotection (zwitterionic form is also accepted with no penalty) -2 points for wrong or undefined stereo-chemistry</p>



No points will be given for structure **A** if it is acyclic.

For wrong isomeric structures of compounds **A–E**, 0–2 points will be given depending on the rationality of the answer.

No points will be given for structures **A–C** or **E** if they do not match the given molecular formulae, except for minor mistakes (see below).

– 1 point for each atom with abnormal valence or for incorrect number of hydrogens on heteroatoms.

In the human body, coprine undergoes hydrolysis to L-glutamic acid (**3**) and compounds **C** and **4**, which are responsible for the coprine adverse side-effects. They inhibit the enzyme acetaldehyde dehydrogenase, which is involved in the metabolism of alcohol. When the enzyme is inhibited, acetaldehyde formed by alcohol dehydrogenase accumulates in the body, causing strong symptoms of hangover (so called antabuse effect). The active site of the enzyme contains a cysteine SH group, which is blocked either by compound **C** or **4**.

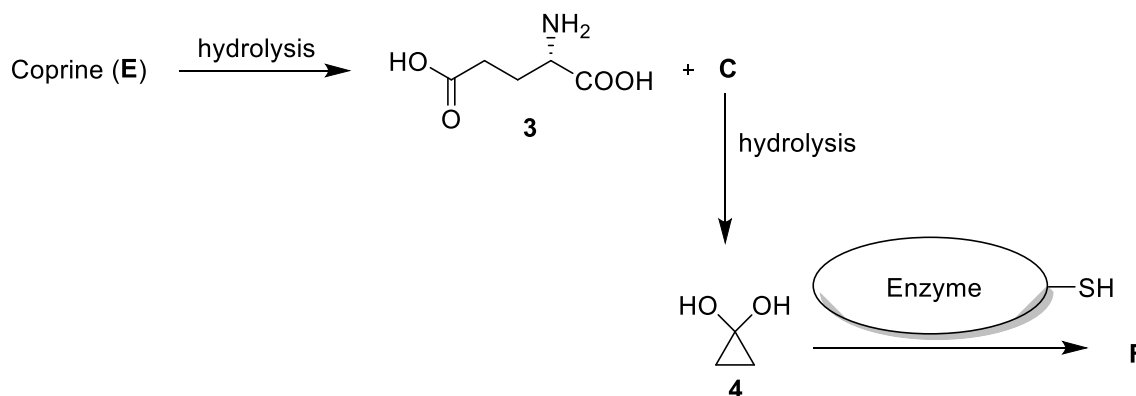

6.2 Using the pictogram for acetaldehyde dehydrogenase above, draw the structure **F** of the enzyme inhibited by compound **4**.

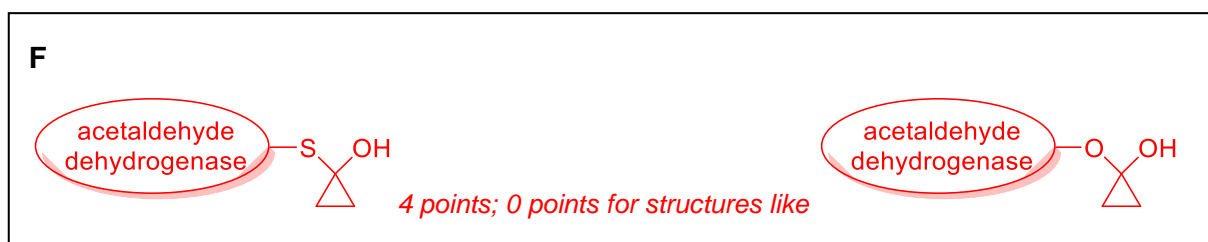

No penalty if two molecules of the enzyme are blocked by one molecule of **4**.

The antabuse effect got its name after antabuse (**5**), the most known drug used in alcohol-addiction treatment. This drug can be synthesized according to the following scheme.

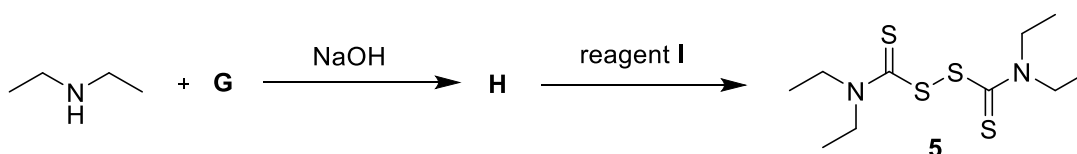



6.3 Draw the formulae of compounds **G** and **H**. *Hint: Compound H contains five carbon atoms.*

<p>G</p> <p>CS_2</p> <p>4 points</p> <p>No penalty for other meaningful reagents, such as halodithioformic acid, its ester or salt.</p> <p>0 points for xanthates.</p>	<p>H</p>  <p>4 points</p> <p>3 points for the above-pictured salt if the cation is wrong or missing</p> <p>2 points for the corresponding acid</p>
---------------------------------------------------------------------------------------------------------------------------------------------------------------------------------------------------	---------------------------------------------------------------------------------------------------------------------------------------------------------------------------------------------------------------------------------------------

6.4 Mark all possible reagents which could be used for **I** from the following list.

- | | |
|--------------------------------------------------------------------------------------|--------------------------------------------------------------------|
| <input checked="" type="checkbox"/> <i>m</i> -chloroperbenzoic acid (<i>m</i> CPBA) | <input checked="" type="checkbox"/> diluted H_2O_2 |
| <input type="checkbox"/> $\text{Zn}/\text{CH}_3\text{COOH}$ | <input type="checkbox"/> NaBH_4 |
| <input checked="" type="checkbox"/> I_2 | <input type="checkbox"/> hot concentrated H_2SO_4 |
| <input type="checkbox"/> $\text{K}_2\text{CO}_3, \text{H}_2\text{O}$ | <input type="checkbox"/> AlCl_3 |

1 point for each correct answer (3 points in total).

-1 point for each incorrect answer. The total score in task 6.4 may not be negative.

The way antabuse inhibits acetaldehyde dehydrogenase is similar to the effect of compounds **C** and **4**.

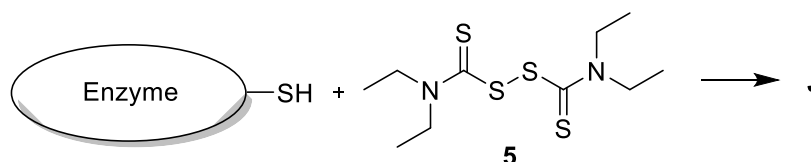

Enzyme = acetaldehyde dehydrogenase

6.5 Using the pictogram for acetaldehyde dehydrogenase above, draw the structure **J** of the enzyme inhibited by antabuse (**5**). *Hint: Three sulfur atoms should be in the structure.*

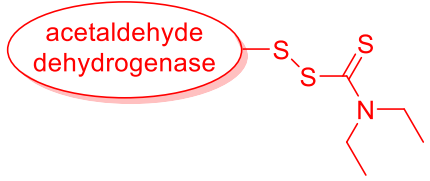
<p>J</p>  <p>4 points (the only acceptable answer)</p>



False morel (*Gyromitra esculenta*) is another interesting mushroom. Although it was considered edible in the past (*esculentus* means edible in Latin), there is clear evidence that this mushroom is poisonous due to the content of gyromitrin (**M**). This natural compound can be prepared from *N*-methylhydrazine (**6**):

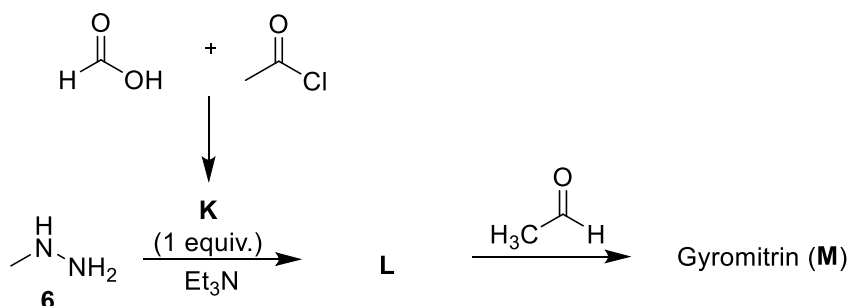

6.6 Draw the formulae of compounds **K–M**.

<p>K</p> <p>4 points 4 points for formic anhydride 2 points for formyl chloride</p>	<p>L</p> <p>4 points for the correct structure - 1 point if acetylated - 1 point for multiple acylation - 2 points if acylated on the other nitrogen atom</p>	<p>M</p> <p>4 points for the correct structure (cis or trans isomer) - 1 point for aminal (exception down below) - 3 points if the reaction with acetaldehyde was carried out on the amidic nitrogen atom</p>
----------------------------------------------------------------------------------------------------	----------------------------------------------------------------------------------------------------------------------------------------------------------------------------------	------------------------------------------------------------------------------------------------------------------------------------------------------------------------------------------------------------------------------

- 1 point for each atom with abnormal valence or for each missing hydrogen atom.

If **L** is acylated with wrong regioselectivity, then in **M** aminals, enamines, and iminium salts are accepted with no penalty.

In human body, gyromitrin (**M**) hydrolyzes and provides *N*-methylhydrazine (**6**), which is strongly hepatotoxic. Gyromitrin (**M**) hydrolysis occurs as soon as it enters the acidic environment in human stomach where both its amide and imine groups are hydrolyzed.

Let us focus on the hydrolysis of the amide moiety within the gyromitrin molecule. The vibrational wavenumber of the stretching mode of the relevant C–N bond amounts to $1\,293.0\text{ cm}^{-1}$ and the potential energy surface does not significantly alter its shape with isotope substitution effect.

6.7 Calculate the highest possible hypothetical kinetic isotope effect at the temperature of human body, $37\text{ }^{\circ}\text{C}$, for the given hydrolysis reaction assuming that both relevant nitrogen and carbon atoms were simultaneously substituted, ^{14}N with the ^{15}N isotope and ^{12}C with the ^{13}C isotope. Consider that only the zero point vibrational energy affects the rate constants. Assume that the molar masses of all isotopes are integers. In all steps consider five significant digits.



C-N bond reduced mass:

$$\mu_{12\text{C}}^{14\text{N}} = \frac{14.000 \text{ g mol}^{-1} \times 12.000 \text{ g mol}^{-1}}{(14.000 + 12.000) \text{ g mol}^{-1} \times 6.0221 \times 10^{23} \text{ mol}^{-1}} = 1.0730 \times 10^{-26} \text{ kg}$$

Alternatively, $(\mu_{12\text{C}}^{14\text{N}})' = 6.4615 \text{ g mol}^{-1}$

$$\mu_{13\text{C}}^{15\text{N}} = \frac{15.000 \text{ g mol}^{-1} \times 13.000 \text{ g mol}^{-1}}{(15.000 + 13.000) \text{ g mol}^{-1} \times 6.0221 \times 10^{23} \text{ mol}^{-1}} = 1.1565 \times 10^{-26} \text{ kg}$$

Alternatively, $(\mu_{13\text{C}}^{15\text{N}})' = 6.9643 \text{ g mol}^{-1}$

C-N bond force constant: $k = \left(2\pi c \tilde{\nu}_{12\text{C}}^{14\text{N}}\right)^2 \times \mu_{12\text{C}}^{14\text{N}} = 636.48 \text{ kg s}^{-2}$

C-N substituted bond wavenumber:

$$\tilde{\nu}_{13\text{C}}^{15\text{N}} = \frac{1}{2\pi c} \sqrt{\frac{k}{\mu_{13\text{C}}^{15\text{N}}}} = 1\,245.5 \text{ cm}^{-1}$$

Hypothetical kinetic isotope effect:

$$\frac{k_{12\text{C}}^{14\text{N}}}{k_{13\text{C}}^{15\text{N}}} = \exp\left(\frac{hc}{2k_{\text{B}}T} \left(\tilde{\nu}_{12\text{C}}^{14\text{N}} - \tilde{\nu}_{13\text{C}}^{15\text{N}}\right)\right) = 1.1166$$

16 points in total

2 points for the correct formula for the reduced mass, 1 point for each numerical value of the reduced mass (4 points in total), full marks will be scored if the reduced mass is given in units such as kg, g, amu, kg mol⁻¹ or g mol⁻¹

2 points for the correct formula for the C-N force constant, 2 points for its numerical value

2 points for the correct formula for the wavenumber, 2 points for its numerical value

2 points for the correct formula for the KIE, 2 points for its numerical value

Alternative to force constant and wavenumber one can derive formula for KIE as follows

$$\tilde{\nu}_{13\text{C}}^{15\text{N}} = \tilde{\nu}_{12\text{C}}^{14\text{N}} \sqrt{\frac{\mu_{12\text{C}}^{14\text{N}}}{\mu_{13\text{C}}^{15\text{N}}}} = 1\,245.5 \text{ cm}^{-1}$$

$$E_{\tilde{\nu}_{12\text{C}}^{14\text{N}}} = \frac{hc\tilde{\nu}_{12\text{C}}^{14\text{N}}}{2} = 1.2851 \times 10^{-20} \text{ J}$$

$$E_{\tilde{\nu}_{13\text{C}}^{15\text{N}}} = \frac{hc\tilde{\nu}_{13\text{C}}^{15\text{N}}}{2} = 1.2379 \times 10^{-20} \text{ J}$$



$$\frac{k_{12\text{C}}^{14\text{N}}}{k_{13\text{C}}^{15\text{N}}} = \exp\left(\frac{E_{\tilde{\nu}_{12\text{C}}^{14\text{N}}} - E_{\tilde{\nu}_{13\text{C}}^{15\text{N}}}}{k_{\text{B}}T}\right) = 1.1166$$

2 points for the correct formula for the wavenumber, 2 points for its numerical value

2 points for the correct formula for the ZPVE, 1 point for each numerical value

2 points for the correct formula for the KIE, 2 points for its numerical value

Some of the steps in the derivation may be taken implicitly or simultaneously. As long as they are correct, full marks will be scored for each of the partial steps. If the correct KIE (a dimensionless quantity) is provided, full marks will be scored for the whole 6.7 problem. If the calculation of the KIE is not completed or its wrong value is given, 0 points will be scored for any of the numerical results of the partial steps if these are given with wrong units or no units at all.

6.8 After making these isotopic changes, the rates of hydrolysis are not significantly different. Which of the following is the most likely the rate determining step?

- Nucleophilic attack of water on a protonated amidic moiety
- C–N bond cleavage
- Protonation of the gyromitrin molecule

3 points for the correct answer.

–3 points for each incorrect answer. The total score in task 6.8 may not be negative.



Theoretical Problem 7	Question	7.1	7.2	7.3	7.4	7.5	7.6	Total
	Points	10	6	15	9	11	6	57
7% of the total	Score							

Problem 7. Cidofovir

Cidofovir (**1**), originally designed and prepared by the group of Professor Holy in former Czechoslovakia, is a nucleotide analogue with antiviral activity. It is used to treat viral infections, mostly in patients with AIDS.

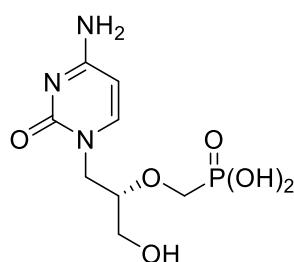

Cidofovir (**1**)

The key intermediate in the synthesis of cidofovir is optically pure diol **2**, which can be prepared from L-mannitol (**3**).

The total for each structure/sub-problem may not be negative.

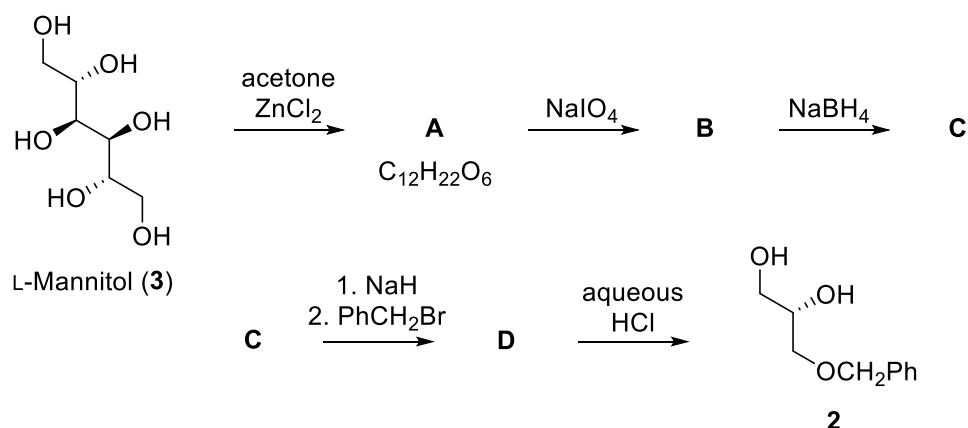

7.1 Draw the structures of compounds **A–D**, including stereochemistry. One molecule of **A** produces two molecules of **B**.

<p>A</p> <p>C₁₂H₂₂O₆</p> <p>3 points for the correct structure 2 points if the molecular formula is correct but different OH groups are protected 2 points if the correct OH groups are protected but the stereochemistry is wrong or missing 1 point if different adjacent OH groups are protected and the stereochemistry is wrong 0 points if the molecular formula is not correct</p>	<p>B</p> <p>3 points for the correct structure 3 points if any wrongly assigned compound A is cleaved between two adjacent free OH groups 2 points if stereochemistry is wrong or missing 1 point if compound A is cleaved properly but the oxidation state of C1 is wrong 1 point if A is not determined and B contains <u>one</u> CHO group 1 point if B contains <u>one</u> CHO group, but the protecting groups are cleaved -1 point if stereochemistry is wrong or missing</p>
<p>C</p> <p>2 points for aldehyde reduction to alcohol (ONa scores full marks) 1 point if B is not determined and C contains a primary OH group -1 point if stereochemistry is wrong or missing</p>	<p>D</p> <p>2 points for alcohol protection ("Bn" also accepted) If C is not correct: 2 points if <u>all</u> primary OH groups are benzyl-protected 1 point if D contains a benzyloxy- group (and not all primary OH groups are benzyl-protected) -1 point if stereochemistry is wrong or missing</p>



7.2 Draw the structural formulae of all alternative stereoisomers of compound **3** which could be used in the same reaction sequence to afford only the same product **2**.

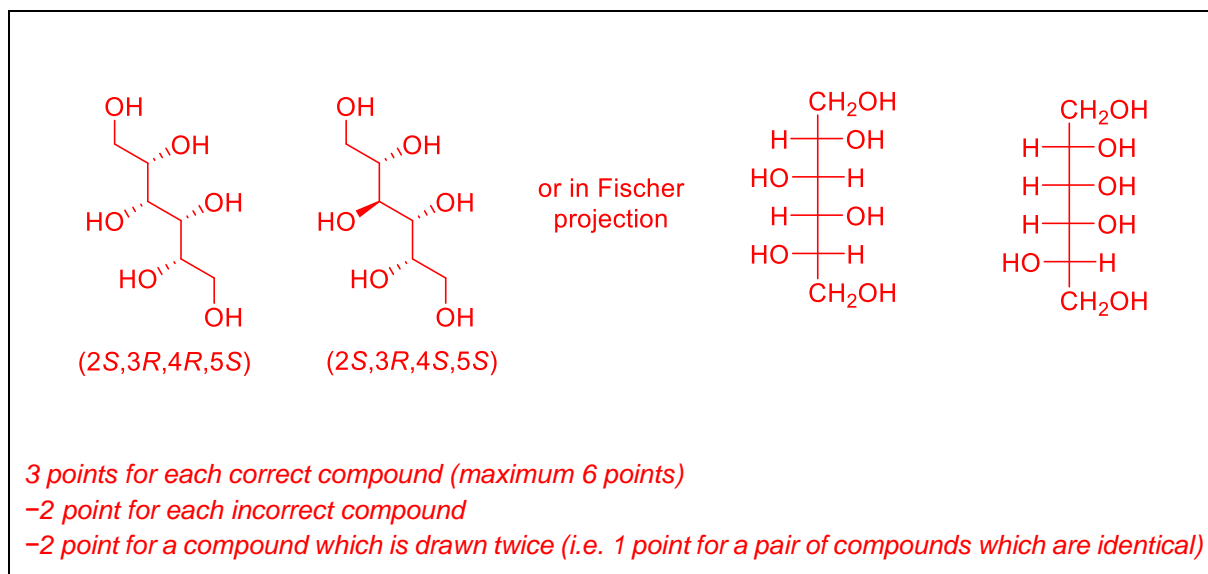

Diol **2** is further modified to provide compound **I**. The synthesis of phosphonate **4** used to convert compound **F** to **G** will be discussed later.

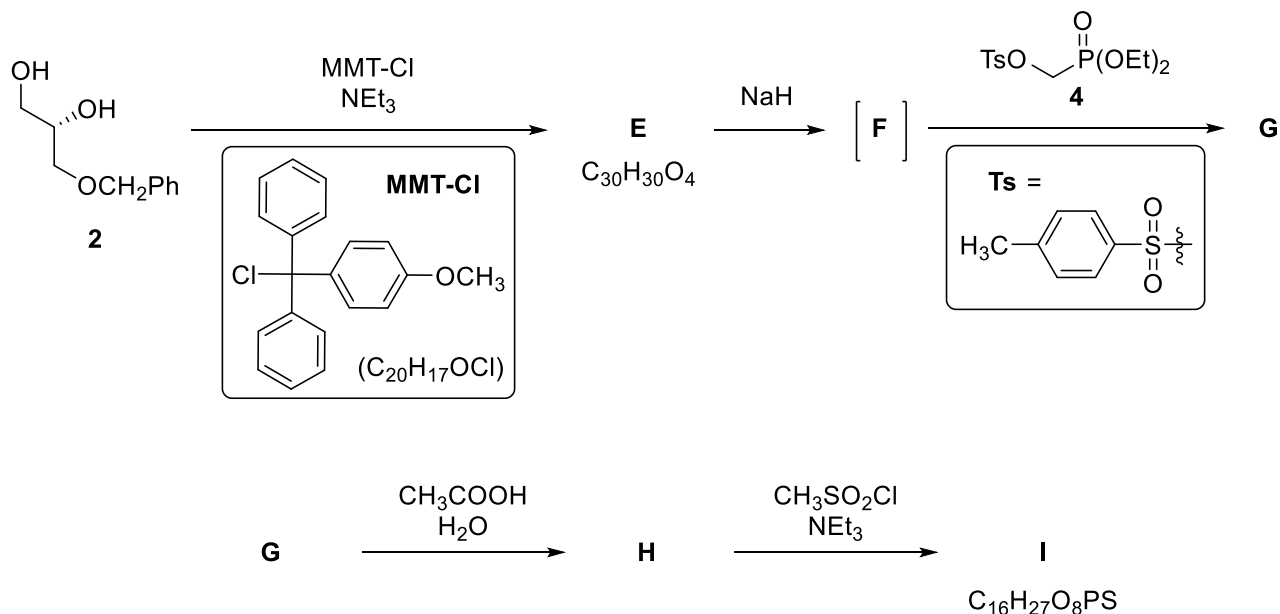



7.3 Draw the structures of compounds **E–I**, including stereochemistry. Use the abbreviation MMT for the (4-methoxyphenyl)diphenylmethyl group.

The same scheme as on the previous page, for easier orientation

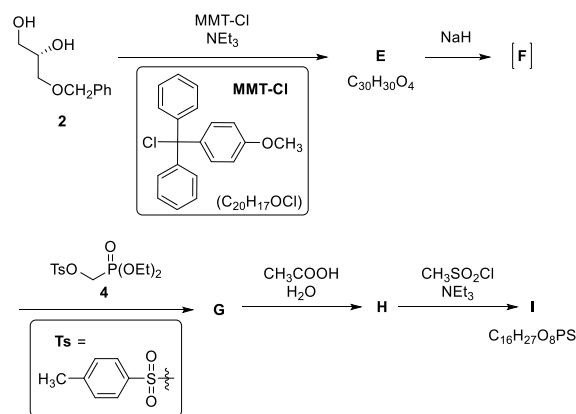
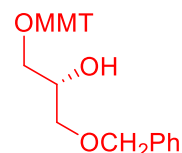
**E** $\text{C}_{30}\text{H}_{30}\text{O}_4$ 

3 points for the correct structure
 1 point if the secondary OH group is protected and the configuration on C2 is correct
 0 points if the secondary OH group is protected and the configuration on C2 is incorrect
 0 points if the molecular formula is not correct
 -1 point if stereochemistry is wrong or missing

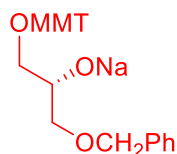
F

3 points for the correct structure)
 2 points if written without the Na^+ counter ion
 1 point if the alkoxide on C2 is formed, but the configuration is inverted
 1 point if the alkoxide on C2 is formed and any of the protecting groups is cleaved
 -1 point if stereochemistry is wrong or missing

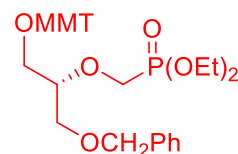
G

3 points for the correct structure
 1 point if the substitution was performed on phosphorus and the configuration on C2 is correct
 -1 point if stereochemistry is wrong or missing

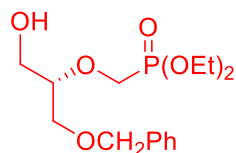
H

3 points for MMT cleavage
 1 point if either benzyl or both the protecting groups are cleaved and the phosphonate is retained with the correct configuration
 -1 point if stereochemistry is wrong or missing

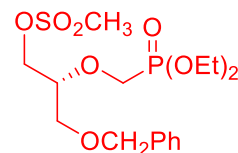
I $\text{C}_{16}\text{H}_{27}\text{O}_8\text{PS}$ 

3 points for the mesylate formation ("Ms" also accepted)
 1 point if the molecular formula is correct, but I contains a mesylate group
 0 points if molecular formula is not correct
 -1 point if stereochemistry is wrong or missing



Phosfonate **4** can be prepared according to the following scheme:

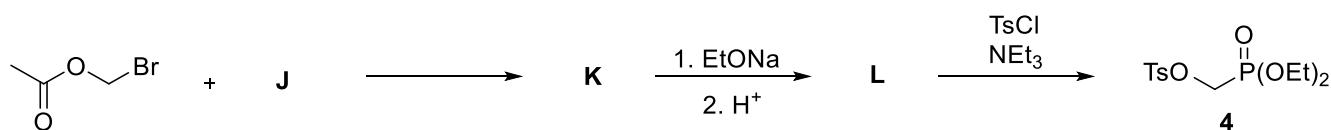

7.4 Draw the structures of compounds **J–L**.

<p>J</p> <p style="text-align: center;"> $\text{P}(\text{OR})_3$ or $\text{Na}^+ \overset{\ominus}{\text{O}} \parallel \text{P}(\text{OR})_2$ </p> <p><i>3 points for any phosphite or dialkyl phosphonate salt</i> <i>Transesterification in the subsequent step would provide the required diethyl phosphonate.</i> <i>1 point if all R = aryl in P(OR)₃</i></p>	<p>K</p> <p style="text-align: center;"> </p> <p style="text-align: center;">or</p> <p style="text-align: center;"> </p> <p><i>3 points for the correct structure</i></p>
<p>L</p> <p style="text-align: center;"> </p> <p><i>3 points for the correct structure</i></p>	

The reaction of **I** (from question 7.3) with cytosine (**5**) leads to a 3:1 mixture of isomeric compounds **M** and **N**. The formation of these two products may be understood by realizing that cytosine (**5**) can also exist as an aromatic tautomer **P**. The reaction of **M** with cyclohexa-1,4-diene and palladium hydroxide on carbon leads to compound **O**. The phosphonic ester moiety in compound **O** reacts with bromotrimethylsilane to provide cidofovir (**1**).

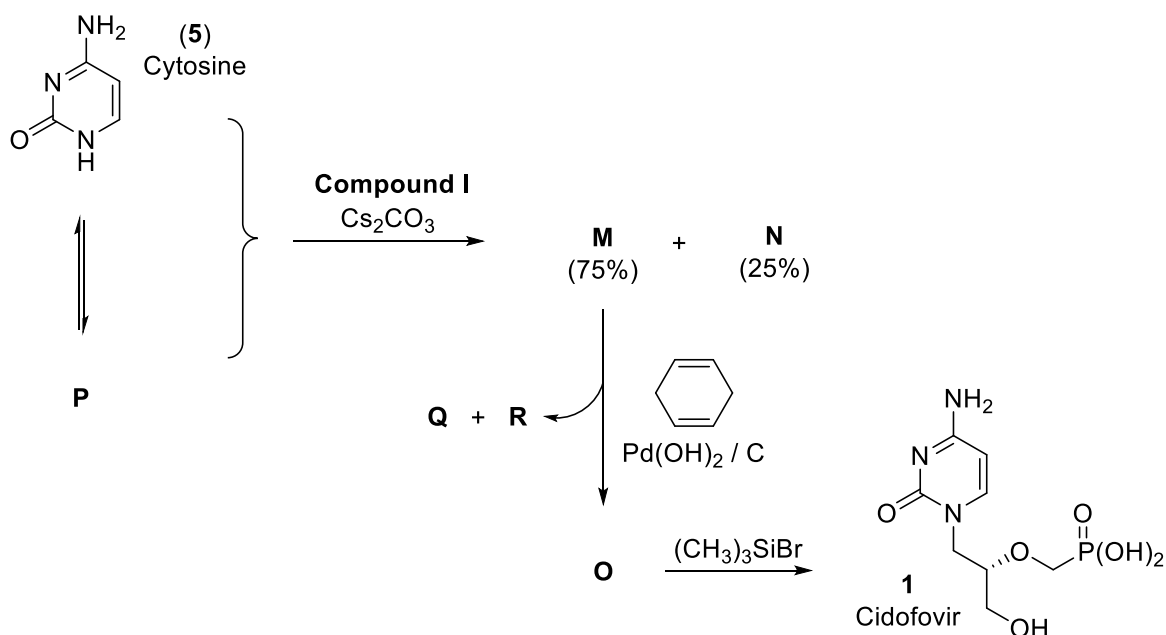

- 7.5 Draw the structures of the two isomers **M**, **N**, and of compound **O**, including stereochemistry and the structure of the aromatic tautomer **P** of cytosine (**5**). Transformation of **M** to **O** is the removal of a protecting group.

<p>M (75%)</p> <p><i>3 points for the correct structure</i> <i>-1 point if the stereochemistry is wrong or missing</i></p>	<p>N (25%)</p> <p><i>3 points for the correct structure</i> <i>2 points if cytosine is linked via the amino group</i> <i>-1 point if the stereochemistry is wrong or missing</i> <i>3 points in total if M and N are interchanged</i></p>
----------------------------------------------------------------------------------------------------------------------------------------	-----------------------------------------------------------------------------------------------------------------------------------------------------------------------------------------------------------------------------------------------------------------

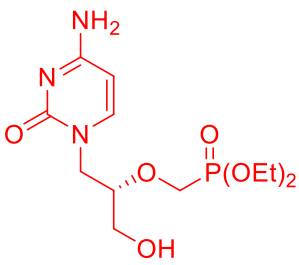
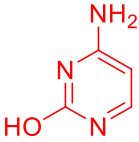

<p>O</p>  <p><i>3 points for the benzyl cleavage -1 point if the stereochemistry is wrong or missing</i></p>	<p>P</p>  <p><i>2 points for the correct aromatic structure</i></p>
----------------------------------------------------------------------------------------------------------------------------------------------------------------------------------------------------------	---------------------------------------------------------------------------------------------------------------------------------------------------------------

7.6 Draw the structures of the two simple organic side products **Q** and **R** formed during the conversion of **M** to **O**.

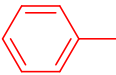
<p>Q from cyclohexadiene</p>  <p><i>3 points for the correct structure</i></p>	<p>R from the protecting group</p>  <p><i>3 points for the correct structure</i></p>
--------------------------------------------------------------------------------------------------------------------------------------------------------------------------	----------------------------------------------------------------------------------------------------------------------------------------------------------------------------------



Theoretical Problem 8 9% of the total	Question	8.1	8.2	8.3	8.4	8.5	8.6	8.7	8.8	Total
	Points	14	14	2	16	6	8	9	6	75
	Score									

Problem 8. Caryophyllene

β -Caryophyllene (**3**) is a naturally occurring sesquiterpene present in clove tree and in some traditional Czech and Slovak plants, such as the hop plant or small-leaved linden.

The synthesis of β -caryophyllene starts from a single enantiomer of dienone **A**. The reaction of **A** with silyl ketene acetal **1**, followed by immediate reduction and aqueous work-up affords ketone **2**. This intermediate then undergoes reaction with tosyl chloride, providing **B**. Basic cyclization of this compound affords **C**. Finally, the reaction of **C** with ylide **D** provides β -caryophyllene.

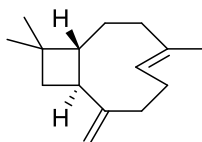

β -Caryophyllene (**3**)

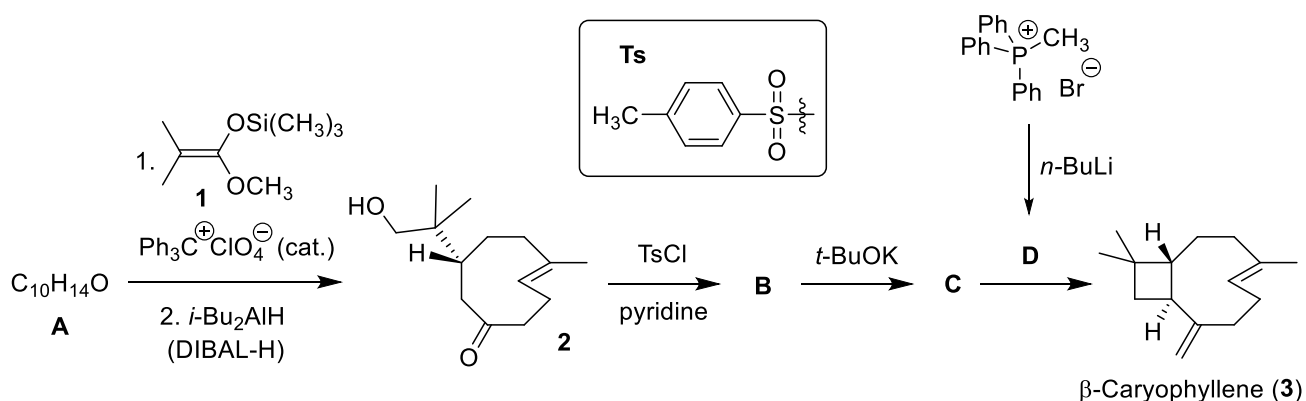

8.1 Draw the structures of compounds **A–D**, including the appropriate stereochemistry. *Hint: In transformation **A** \rightarrow **2**, the silyl ketene acetal acts as a nucleophile.*

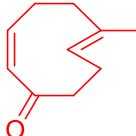
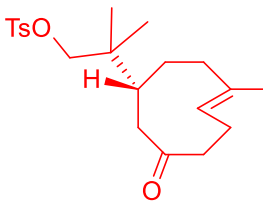
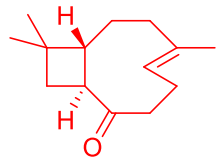
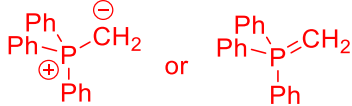
<p>A $C_{10}H_{14}O$</p>  <p>4 points 2 points if configuration on C2-C3 double bond is (E) 1 point for the β,γ-unsaturated isomer of A</p>	<p>B</p>  <p>4 points 2 points if stereo configuration is incorrect or unclear</p>
<p>C</p>  <p>4 points 2 points if stereo configuration is incorrect or unclear</p>	<p>D</p>  <p>2 points</p>



Due to the large ring size, both compounds **2** and **3** are stable, even though they contain a double bond in the *trans* configuration. *trans*-Cyclooctene (**4**) is the smallest ring that can accommodate a *trans* double bond. It can be prepared according to the following scheme:

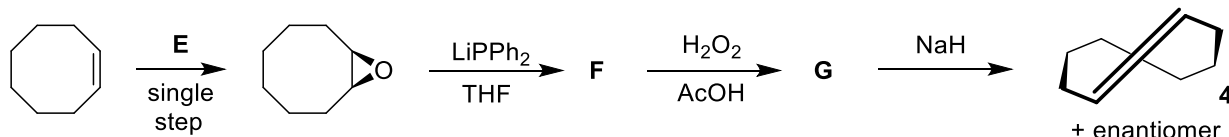

8.2 Draw the structures of reagent **E** and intermediates **F** and **G**, including the appropriate stereochemistry. For **F** and **G**, tick the box indicating the stereochemical outcome.

<p>E</p> <div style="text-align: center;"> </div> <p style="text-align: center;">2 points Other common epoxidation agents are also accepted. 1 point if a two-step epoxidation is given 0 points for H₂O₂ (with no acid indicated)</p>	<p>F</p> <div style="text-align: center;"> </div> <p style="text-align: center;">4 points for the structure (O⁻Li⁺ and OH are also accepted) 3 points when Li cation is missing from OLi 2 points if stereochemistry is incorrect or unclear</p> <p style="text-align: center;">2 points for ticking the right box (these points are additive to the points for the structure)</p> <p> <input type="checkbox"/> achiral <input type="checkbox"/> single enantiomer <input checked="" type="checkbox"/> racemic mixture <input type="checkbox"/> mixture of diastereoisomers </p>
<p>G</p> <div style="text-align: center;"> </div> <p style="text-align: center;">4 points for the structure 4 points for the oxidized product with acetylated -OH 3 points if charges and/or multiple bonds on phosphine oxide are incorrect or missing 2 points if stereochemistry is incorrect or unclear 1 point for oxidizing the alcohol to a ketone instead of or in addition to the phosphine 0 points for only acetylating -OH 2 points for ticking the right box (these points are additive to the points for the structure)</p> <p> <input type="checkbox"/> achiral <input type="checkbox"/> single enantiomer <input checked="" type="checkbox"/> racemic mixture <input type="checkbox"/> mixture of diastereoisomers </p>	



8.3 Draw the structure of the enantiomer of cycloalkene **4**.

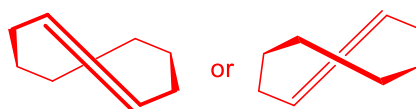
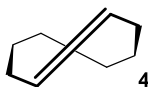

2 points (other correct drawings are also accepted)

The two double bonds in β -caryophyllene display different reactivity: the double bond in the ring (endocyclic) is more reactive than the other one (exocyclic) due to the ring strain.

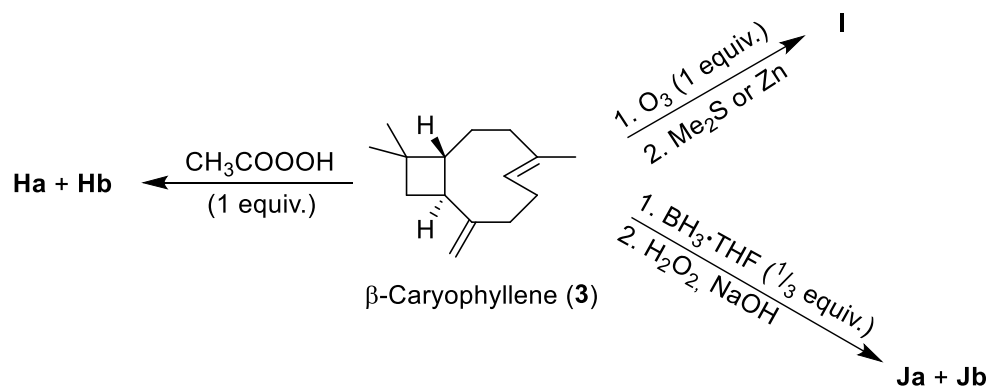

8.4 Draw the structures of compounds **Ha + Hb**, **I** and **Ja + Jb**, including the appropriate stereochemistry. *Hint: **Ha + Hb** and **Ja + Jb** are pairs of diastereomers.*

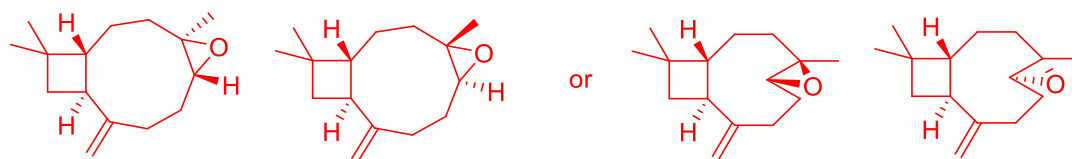
**Ha + Hb**

6 points if both diastereomers are given

4 points if both diastereomers are given but stereochemistry of one of the two newly formed stereocenters is missing, unclear or incorrect

4 points if only one diastereomer is given (the second is missing) but stereochemistry is correct

3 points if one diastereomer is drawn correctly and the second structure is incorrect

2 points if both diastereomers are given but stereochemistry is incorrect or missing

2 points if both diastereomers are given but incorrect double bond or both double bonds are syn-epoxidized

1 point if only one diastereomer is given and stereochemistry is incorrect or missing

1 point if only one diastereomer is given and incorrect double bond or both double bonds are syn-epoxidized

the above partial credit points are not additive

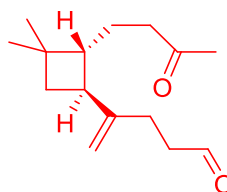
I

4 points

2 points if primary or secondary ozonide is drawn

1 point if the correct ozonolysis product of the exocyclic bond or of both bonds is given

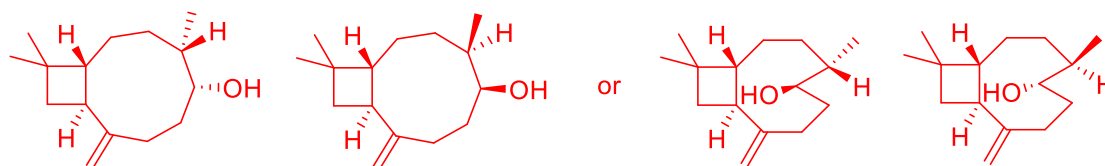
Ja + Jb

6 points if both diastereomers are given

4 points if both diastereomers are given but stereochemistry of one of the two newly formed stereocenters is missing, unclear or incorrect

4 points if only one diastereomer is given (the second is missing) but stereochemistry is correct

3 points if one diastereomer is drawn correctly and the second structure is incorrect

2 points if both diastereomers are given but stereochemistry is incorrect or missing

2 points if both diastereomers are given but regioselectivity is incorrect

2 points if both diastereomers are given but correct hydration of the wrong double bond or of both double bonds is given

1 point if only one diastereomer is given and stereochemistry is incorrect or missing

1 point if only one diastereomer is given and regioselectivity is incorrect

1 point if only one diastereomer is given and incorrect double bond or both double bonds are correctly syn-hydrated

the above partial credit points are not additive



Interestingly, the reactivity of the double bonds is reversed when isocaryophyllene (**5**) is used instead of β -caryophyllene (**3**).

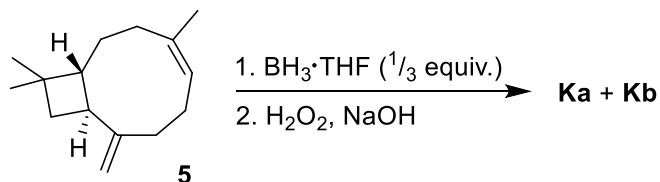

8.5 Draw the structures of compounds **Ka** and **Kb**. *Hint: **Ka** + **Kb** are a pair of diastereomers.*

Ka + Kb

6 points if both diastereomers are given
4 points if only one diastereomer is given (the second is missing) but stereochemistry is correct
3 points if one diastereomer is drawn correctly and the second structure is incorrect
2 points if both diastereomers are given but stereochemistry is incorrect or missing
2 points if both diastereomers are given but regioselectivity is incorrect
2 points if both diastereomers are given but correct hydration of the wrong double bond or of both double bonds is given
1 point if only one diastereomer is given and stereochemistry is incorrect or missing
1 point if only one diastereomer is given and regioselectivity is incorrect
1 point if only one diastereomer is given and incorrect double bond or both double bonds are correctly syn-hydrated
the above partial credit points are not additive

Isotope-labelled compounds are invaluable tools for reaction mechanism investigation, structure determination, and mass or NMR spectroscopy studies. Let us have a look at the synthesis of some labelled analogues of β -caryophyllene.

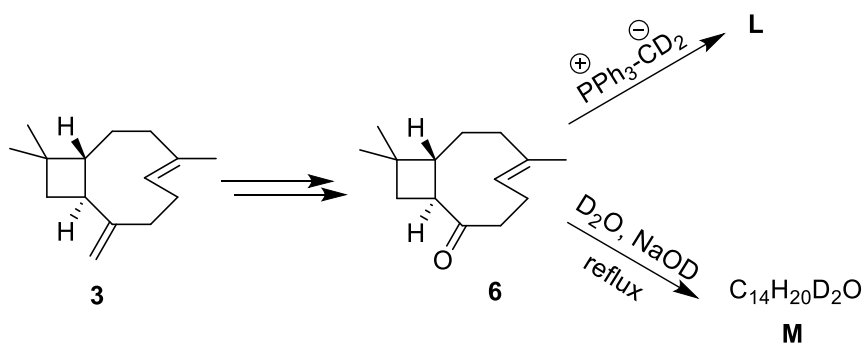

8.6 Draw the structures of compounds **L** and **M**, including the appropriate stereochemistry.



<p>L</p> <p>4 points</p>	<p>M C₁₄H₂₀D₂O</p> <p>4 points</p> <p>2 points for the structure below</p>
---------------------------------	--------------------------------------------------------------------------------------------------------------------

β -Caryophyllene (**3**) undergoes acid-catalyzed cyclization, which leads to a complex mixture of products. Among them, the pair of diastereomers **Na** + **Nb** and the pair of diastereomers **7a** + **7b** are the most abundant. The reaction starts with protonation of the more reactive internal double bond affording cation **O**. This cyclizes without the cleavage of a carbon-carbon single bond to yield diastereomeric tricyclic cations **Pa** and **Pb**, which undergo hydration to give the target alcohols **Na** and **Nb**. Alternatively, the cations **Pa** and **Pb** rearrange with the cleavage of a carbon-carbon single bond to cations **Qa** and **Qb**, which deprotonate to compounds **7a** and **7b**.

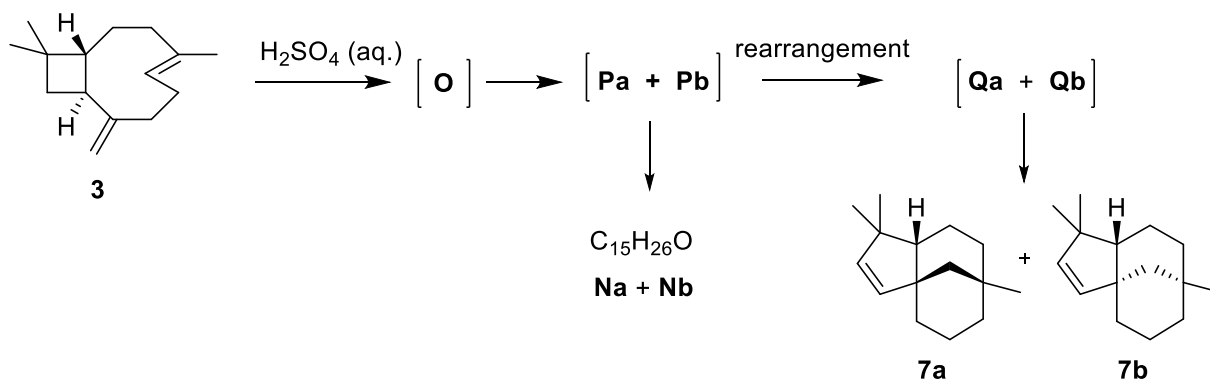

8.7 Draw the structures, including the appropriate stereochemistry, of the **three** intermediates **O**, **Pa**, **Qa** leading to the diastereomer **7a**, including the appropriate stereochemistry.

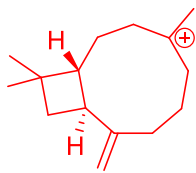
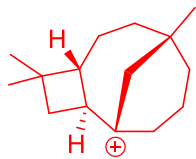
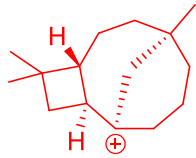
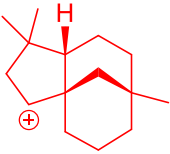
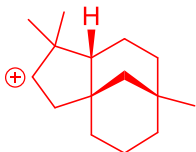
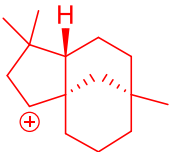

<p>O</p>  <p style="text-align: center;">O</p> <p><i>3 points for the correct structure 2 points if stereochemistry is missing or incomplete 1 point if the wrong double bond is protonated with correct regioselectivity 0 points if either double bond is protonated with incorrect regioselectivity</i></p>	<p>Pa</p>  <p style="text-align: center;">Pa</p> <p><i>3 points for the correct structure 2 points for the carbocation with incorrect regioselective ring closure 1 point if stereochemistry is missing or incomplete 2 points for structure Pb</i></p>  <p style="text-align: center;">Pb</p>
<p>Qa</p>  <p style="text-align: center;">Qa</p>  <p style="text-align: center;">incorrect Qa'</p> <p><i>3 points for the correct structure 2 points for the carbocation with incorrect regioselective rearrangement 1 point if stereochemistry is missing or incomplete 2 points for structure Qb 2 points for incorrect cation Qa'</i></p>  <p style="text-align: center;">Qb</p>	

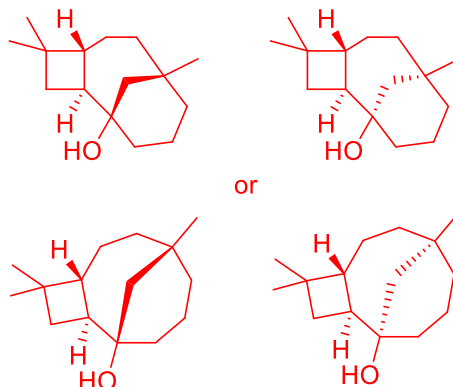
8.8 Draw the structures of diastereomers **Na + Nb**.**Na + Nb** C₁₅H₂₆O

6 points if both diastereomers are given

4 points if only one diastereomer is given

4 points if both diastereomers are given which are tricyclic compounds resulting from a regioisomeric attack on the correct carbocation (see example below)

2 points if both diastereomers are given which are tricyclic compounds resulting from an attack on incorrect carbocation (see example below)

2 points if only one diastereomer is given which is a tricyclic compound resulting from a regioisomeric attack on the correct carbocation (see example below)

1 point if only one diastereomer is given which is a tricyclic compound resulting from an attack on an incorrect carbocation (see example below)

- incorrect regioisomeric attack on the correct carbocation intermediate

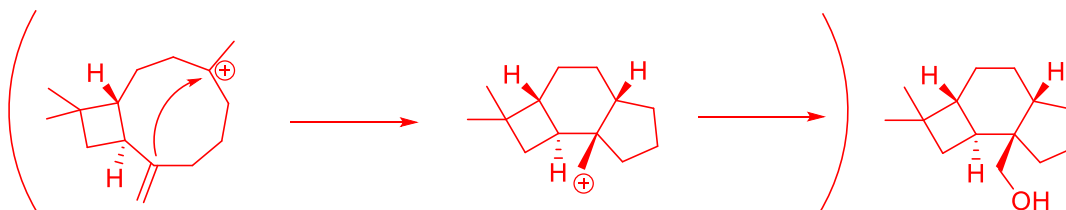

- attack on the incorrect carbocation intermediate

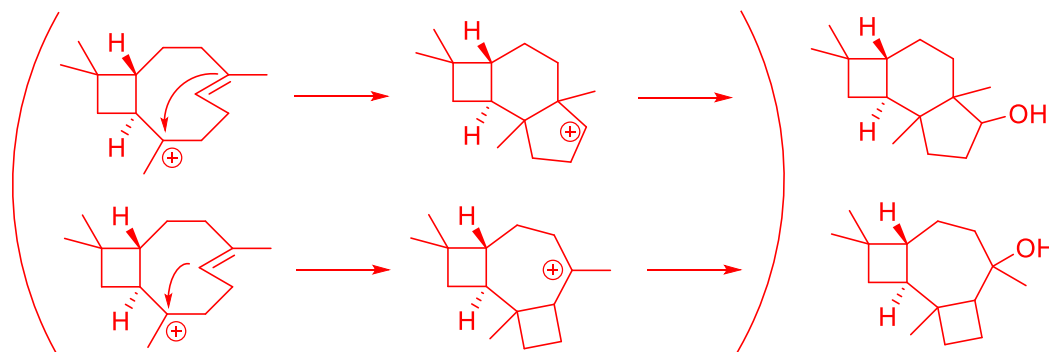

19th – 29th July 2018
Bratislava, SLOVAKIA
Prague, CZECH REPUBLIC

www.50icho.eu

PRACTICAL PROBLEMS

Country:	
Name as in passport:	
Student code:	
Language:	



50th IChO 2018

International Chemistry Olympiad
SLOVAKIA & CZECH REPUBLIC

BACK TO WHERE IT ALL BEGAN



General instructions

- This practical exam booklet contains 28 pages.
- Before the start of the exam, you will have additional 15 minutes to read the exam booklet. **Do not work, write or calculate during this time, otherwise you will be disqualified.**
- You may begin working as soon as the **Start** command is given.
- You have **5 hours** to complete the exam.
- You may work on the tasks in any order, but starting with Problem P1 is recommended.
- All results and answers must be clearly written **in pen in their respective designed areas** on the exam papers. Answers written outside the answer boxes will not be graded.
- Do not use a pencil or a marker to write the answers. Use only the pen and calculator provided.
- You were provided with 3 sheets of scratch paper. If you need more, use the backside of the exam sheets. Remember that **nothing outside the designed areas will be graded.**
- **The official English version** of the exam booklet is available upon request and serves for clarification only.
- If you need to leave the laboratory (to use the toilet or have a drink or snack), tell your lab assistant. He or she will come to accompany you.
- You must **follow the safety rules** given in the IChO regulations. If you break the safety rules, you will receive only one warning from the lab assistant. Any safety rule violations after the first warning will result in your dismissal from the laboratory and 0 marks for the entire practical examination.
- Chemicals and labware, unless otherwise noted, will be refilled or replaced without penalty only for the first item. Each further incident will result in the deduction of 1 point from your 40 practical exam points.
- The lab assistant will announce a 30 minute warning before the **Stop** command.
- You must stop your work immediately when the **Stop** command is announced. Failure to stop working or writing by one minute or longer will lead to nullification of your practical exam.
- After the **Stop** command has been given, a lab assistant will come to sign your answer sheet. After both the assistant and you sign, place this exam booklet back in the exam envelope and submit it for grading together with your products and TLC plates.



Lab rules and safety

- You must wear a lab coat and keep it buttoned up. Footwear must completely cover the foot and heel.
- Always wear safety glasses or prescription glasses when working in the lab. Do not wear contact lenses.
- Do not eat or drink in the lab. Chewing gums are not allowed.
- Work only in the designed area. Keep your work area and the common work areas tidy.
- No unauthorized experiments are allowed. No modification of the experiments is allowed.
- Do not pipet with your mouth. Always use a bulb pipette filler.
- Clean up spills and broken glassware immediately from both the bench and the floor.
- All waste must be properly discarded to prevent contamination or injury. Non-hazardous water soluble/miscible lab waste is eligible for sink disposal. Other lab waste must be disposed of in a marked capped container.



Definition of GHS hazard statements

The GHS hazard statements (H-phrases) associated with the materials used are indicated in the problems. Their meanings are as follows.

Physical hazards

- H225 Highly flammable liquid and vapour.
- H226 Flammable liquid and vapour.
- H228 Flammable solid.
- H271 May cause fire or explosion; strong oxidizer.
- H272 May intensify fire; oxidizer.
- H290 May be corrosive to metals.

Health hazards

- H301 Toxic if swallowed.
- H302 Harmful if swallowed.
- H304 May be fatal if swallowed and enters airways.
- H311 Toxic in contact with skin.
- H312 Harmful in contact with skin.
- H314 Causes severe skin burns and eye damage.
- H315 Causes skin irritation.
- H317 May cause an allergic skin reaction.
- H318 Causes serious eye damage.
- H319 Causes serious eye irritation.
- H331 Toxic if inhaled.
- H332 Harmful if inhaled.
- H333 May be harmful if inhaled.
- H334 May cause allergy or asthma symptoms or breathing difficulties if inhaled.
- H335 May cause respiratory irritation.
- H336 May cause drowsiness or dizziness.
- H351 Suspected of causing cancer.
- H361 Suspected of damaging fertility or the unborn child.
- H371 May cause damage to organs.
- H372 Causes damage to organs through prolonged or repeated exposure.
- H373 May cause damage to organs through prolonged or repeated exposure.

Environmental hazards

- H400 Very toxic to aquatic life.
- H402 Harmful to aquatic life.
- H410 Very toxic to aquatic life with long lasting effects.
- H411 Toxic to aquatic life with long lasting effects.
- H412 Harmful to aquatic life with long lasting effects.



Chemicals

For all problems

Chemicals	Labelled as	GHS hazard statements ¹
Deionized water in: Wash bottle (bench) Plastic bottle (bench) Plastic canister (hood)	Water	Not hazardous

For Problem P1 (in white basket if not stated otherwise)

Chemicals	Labelled as	GHS hazard statements ¹
Ethanol , 100 cm ³ in wash bottle (bench)	Ethanol	H225, H319
2-Acetonaphthone : ca. 0.002 g in glass vial, standard for TLC 0.500 g in glass vial	Standard A	H302, H315, H319, H335, H411
	Reactant A	
2,4-Dinitrophenylhydrazine , containing 33% (w/w) of water, 0.300 g in glass vial	DNPH	H228, H302
Bleach solution, containing 4.7% of NaClO , 13.5 cm ³ in amber glass bottle	Bleach	H290, H314, H400
Ethyl acetate , 15 cm ³ in amber glass bottle	EtOAc	H225, H319, H336
Eluent for thin layer chromatography, hexanes/ethyl acetate 4:1 (v/v), 5 cm ³ in amber glass bottle	TLC eluent	H225, H304, H315, H336, H411 ²
5% Na₂CO₃ , aqueous solution, 20 cm ³ in plastic bottle	5% Na₂CO₃	H319
20% HCl , aqueous solution, 15 cm ³ in plastic bottle	20% HCl	H290, H314, H319, H335 and others

For Problem P2 (in green basket)

Chemicals	Labelled as	GHS hazard statements ¹
8 mmol dm ⁻³ luminol in 0.4 mol dm ⁻³ NaOH aqueous solution, 50 cm ³ in plastic bottle	Luminol in NaOH	H290, H315, H319
2.00 mmol dm ⁻³ CuSO₄ aqueous solution, 25 cm ³ in plastic bottle	Cu	Not hazardous
2.00 mol dm ⁻³ H₂O₂ aqueous solution, 12 cm ³ in small plastic bottle	H₂O₂ conc.	H302, H315, H318
0.100 mol dm ⁻³ cysteine hydrochloride aqueous solution, 12 cm ³ in small plastic bottle	Cys conc.	Not hazardous
Water , 50 cm ³ in plastic bottle	Water	Not hazardous

¹ See page 3 for the definition of the GHS hazard statements.

² The GHS hazard statements for hexanes.



For Problem P3 (in grey basket if not stated otherwise)

Chemicals	Labelled as	GHS hazard statements ¹
Sample of mineral water, 400 cm ³ in plastic bottle (bench)	Sample	Not hazardous
3 mol dm ⁻³ NH ₄ Cl / 3 mol dm ⁻³ NH ₃ solution in water, 15 cm ³ in plastic bottle	Buffer	H302, H319, H314, H400
NaCl, solid, 10 g in plastic bottle	NaCl	H319
Eriochrome black T, indicator mixture in plastic bottle	EBT	H319
Bromothymol blue, indicator solution in plastic bottle	BTB	H302, H315, H319
5.965 × 10 ⁻³ mol dm ⁻³ disodium ethylenediamine tetraacetate standard solution, 200 cm ³ in plastic bottle (bench)	EDTA	H302, H315, H319, H335
0.2660 mol dm ⁻³ NaOH standard solution, 250 cm ³ in plastic bottle (bench)	NaOH	H314
Strong acidic cation exchange resin, in H ⁺ form, 50 cm ³ of swollen material washed with deionized water in plastic bottle	Catex	H319

Equipment

For all problems (on shelf if not stated otherwise)

Shared equipment	Quantity
Paper wipes	1 box for 2–4
Waste paper basket (bench, close to sink)	1 for 4
Nitrile gloves (hood)	1 box for lab
Personal equipment	
Safety goggles	1
Pipette stand (bench)	1
Bulb pipette filler	1
Glass beaker, 100 cm ³ , containing: glass rod, plastic spoon, spatula, tweezers, marker, pencil, ruler	1 (each)

For Problem P1 (in white basket if not stated otherwise)

Shared equipment	Quantity
UV lamp (hood)	1 for up to 12
Vacuum source (plastic stopcock with vacuum hose, bench)	1 for 2
Personal equipment	
Hotplate stirrer (bench) with: Temperature probe, Crystallizing dish, with metallic clip	1 (each)



Laboratory stand (bench) with: Clamp holder with small clamp Clamp holder with large clamp	1 (each)
Organic waste plastic bottle (bench)	1
Open metal ring	1
Round bottom flask, 50 cm ³ , with magnetic stir bar	1
Measuring cylinder, 10 cm ³	1
Reflux condenser	1
Separatory funnel, 100 cm ³ , with stopper	1
Erlenmeyer flask without ground joint, 50 cm ³	1
Erlenmeyer flask without ground joint, 25 cm ³	1
Erlenmeyer flask with ground joint, 50 cm ³	1
Glass funnel	1
Suction flask, 100 cm ³	1
Rubber adapter for filter funnel	1
Fritted glass filter funnel, porosity S2 (white label)	1
Fritted glass filter funnel, porosity S3 (orange label)	1
Glass beaker, 50 cm ³ , with Petri dish lid	1
Glass beaker, 150 cm ³	1
TLC graduated capillary spotter, 5 µl	3
Zippered bag with 5 pH indicator strips and 1 pH scale	1
Zippered bag with 2 TLC plates	1
Glass Pasteur pipette	4
Rubber bulb	1
Glass vial labelled Student code B for the product of the haloform reaction	1
Glass vial labelled Student code C for the product of the reaction with Brady's reagent	1

For Problem P2 (in green basket if not stated otherwise)

Personal equipment	Quantity
Stopwatch	1
Digital thermometer and card with its calibration constant	1
Volumetric flask, 50 cm ³	1
Bulb pipette, 5 cm ³ (bench, in pipette stand)	1
Graduated pipette, 5 cm ³ (bench, in pipette stand)	3
Graduated pipette, 1 cm ³ (bench, in pipette stand)	2
Plastic bottle labelled H₂O₂ dil. for diluted stock solution of H ₂ O ₂ , 50 cm ³	1
Plastic bottle labelled Cys dil. for diluted stock solution cysteine.HCl, 50 cm ³	1
Black plastic test tube, 15 cm ³	1
Capless centrifuge tube, 1.5 cm ³	1



Plastic beaker, 25 cm ³	1
Erlenmeyer flask, 100 cm ³	1

For Problem P3 (in grey basket if not stated otherwise)

Personal equipment	Quantity
Laboratory stand (bench) with: White sheet of paper Burette clamp Burette, 25 cm ³	1 (each)
Bulb pipette, 50 cm ³ (bench, in pipette stand)	1
Bulb pipette, 10 cm ³ (bench, in pipette stand)	1
Glass funnel	1
Measuring cylinder, 5 cm ³	1
Titration flask (flat bottom flask), 250 cm ³	2
Erlenmeyer flask, 250 cm ³	1
Fritted glass filter funnel, porosity S1 (blue label)	1
Glass beaker, 100 cm ³	2
Glass beaker, 250 cm ³	1
Plastic Pasteur pipette, narrow stem, nongraduated	2
Plastic Pasteur pipette, thick stem, graduated	1
Zippered bag with 5 pH indicator strips and 1 pH scale	1
Zippered bag with 5 absorbing paper strips	1
Waste catex plastic bottle (bench)	1



Practical Problem P1 14% of the total	Question	1.1	1.2	yield	m.p.	Total
	Points	4	16	20	10	50
	Score					

Problem P1. Haloform reaction with bleach

Chemical test reactions have been developed as a means of identifying functional groups in unknown compounds. In this task, you will explore two examples of chemical test reactions on a preparatory scale, starting from (2-naphthyl)ethanone (**A**, 2-acetonaphthone):

- The haloform reaction is a transformation typical for methyl ketones which react with basic aqueous hypochlorite solution and provide a carboxylic acid (product **B**) and a haloform (trihalomethane).
- The reaction of Brady's reagent (acidic solution of 2,4-dinitrophenylhydrazine) with the carbonyl group of an aldehyde or ketone results in the formation of an orange hydrazone precipitate (product **C**).

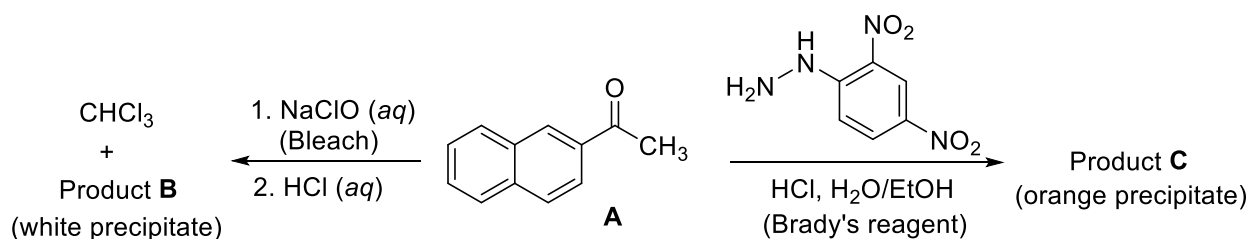

P1.1 Draw the structures of products **B** and **C**.

 <p><i>2 points (1 point for 2-naphthoate)</i></p> <p>Product B</p>	 <p><i>2 points (1 point for intermediate hydrazine-alcohol or the product with minor mistake in the structure – forgotten group or hydrogen atoms in the side chain)</i></p> <p>Product C</p>
-------------------------------------------------------------------------------	----------------------------------------------------------------------------------------------------------------------------------------------------------------------------------------------------------

Notes:

- The total score will be based on the R_f values of compounds **A** and **B** calculated from the submitted TLC plate 1 and on the quality and quantity of the submitted products **B** and **C**.
- The quality of your products will be graded based on the TLC and melting points.
- The amount of the provided hypochlorite solution is not sufficient to convert all reactant **A** to product **B**. You will recover the residual reactant **A** by an acid-base extraction and isolate it after



the reaction with Brady's reagent as hydrazone **C**. The grading is based on the combined yield of products **B** and **C**.

Procedure

I. Haloform reaction

1. Turn on the stirrer and adjust the speed to 540 rpm. Immerse a temperature probe, resting the wire on the upper clamp into the bath almost to the bottom and set the temperature to 80 °C.
2. Transfer the 0.500 g of 2-acetonaphthone from the vial labelled **Reactant A** into a 50 cm³ round bottom flask that contains a magnetic stir bar. Measure 3 cm³ of ethanol (from the wash bottle) in a measuring cylinder and use it to transfer the remaining reactant **A** quantitatively into the round bottom flask using a glass Pasteur pipette.
3. Place the round bottom flask into the hot water bath. Attach an air reflux condenser (water connection is not needed) and secure it in the upper part by a loosely attached large clamp, as shown in Figure 1. Let compound **A** dissolve with stirring.

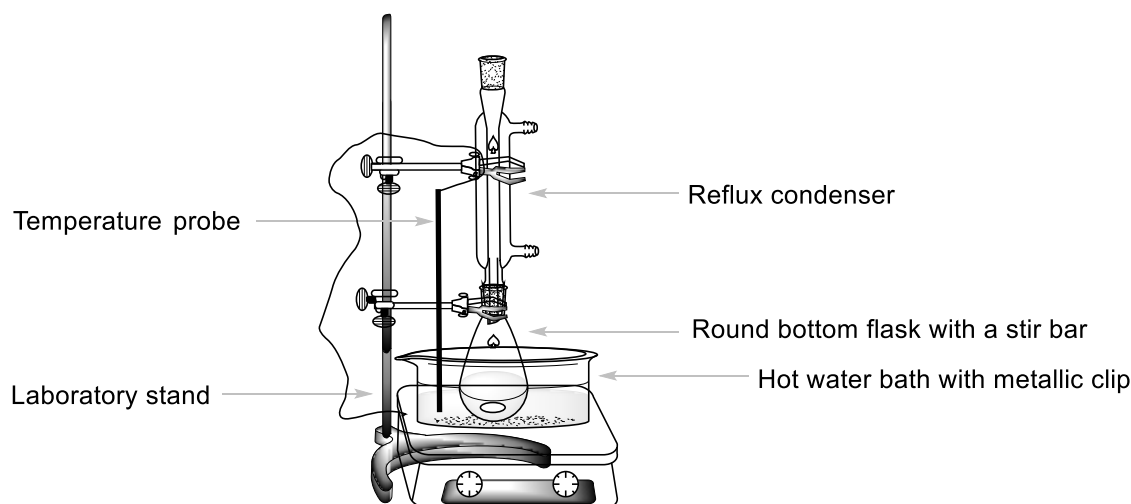

Figure 1. Setup for heating the reaction mixture in a water bath.

4. When the bath temperature reaches 75 °C, slowly add all the NaClO solution (**Bleach**) to the reaction mixture through the top opening of the condenser using a small glass funnel. Heat the reaction mixture with stirring for 60 minutes between 75 and 80 °C.
5. Then turn off the heating of the hotplate stirrer. Loosen the upper clamp a bit and lift the reaction flask over the water bath. (*Caution!* Touch only the clamps, the flask is hot.) Allow the reaction mixture to cool down for 15 minutes.

II. Workup of the reaction mixture

1. Place a separatory funnel into a metal ring and place a 50 cm³ Erlenmeyer flask without a ground joint under it. Using a glass funnel, pour the cooled reaction mixture into the separatory funnel. Remove the stir bar from the glass funnel with tweezers. Measure 5 cm³ of ethyl acetate (**EtOAc**) and use it to rinse the reaction flask.. Add the washings into the separatory funnel using a glass Pasteur pipette.



- Perform the extraction. Allow the layers to separate. Collect the aqueous layer into the 50 cm³ Erlenmeyer flask without a ground joint. Using a small glass funnel, pour the organic layer through the top neck into the 25 cm³ Erlenmeyer flask. Keep both phases!
- Using a small funnel, pour the aqueous phase from the 50 cm³ Erlenmeyer flask back to the separatory funnel. Measure another 5 cm³ of ethyl acetate and repeat the extraction (step No. II.2). Combine the organic phases together in the 25 cm³ Erlenmeyer flask. Keep both phases!
- Prepare your TLC plate. Check it before use. Unused damaged plates will be replaced upon request without penalty. Use a pencil to draw the start line and mark the positions for spotting the samples. Write number **1** in a circle and your student code on the top of the TLC plate as shown in Figure 2. Dissolve the given sample of 2-acetonaphthone in a vial (**Standard A**) in ca. 2 cm³ of ethanol (about 1 full glass Pasteur pipette). Mark three spot positions and label them **A**, **O1**, and **O2**. Spot 1 μl (one mark of the 5 μl capillary spotter) of standard **A** and the combined organic phase from step II.3 (**O1**). You will add spot **O2** later.

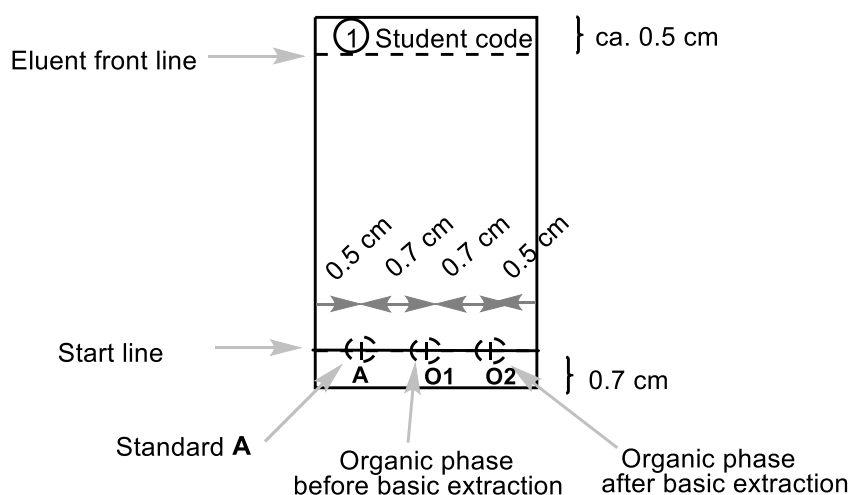

Figure 2. Instructions for the TLC plate preparation.

- Extract the combined organic phases twice with 5 cm³ of 5% Na₂CO₃ solution. Collect the aqueous phase into the same 50 cm³ Erlenmeyer flask without a ground joint containing the aqueous phase from the first extraction.
- Wash the organic phase in the funnel with 5 cm³ of deionized water. Add the aqueous phase to the combined aqueous extracts. Pour the organic layer (**O2**) through the top neck into a 50 cm³ ground-joint Erlenmeyer flask. Spot 1 μl of the solution **O2** on your TLC plate prepared in step II.4 (Plate 1).
- Perform a TLC analysis. Take a 50 cm³ beaker and load it with ca. 2 cm³ of the **TLC eluent**. Insert the TLC plate, cover the beaker with a Petri dish and let the eluent reach approximately 0.5 cm below the top edge of the plate. Using tweezers, take the TLC plate out, draw the eluent front line and let the plate air-dry. Place the TLC plate under the UV lamp in the hood. With a pencil, circle all the visualized spots and calculate the *R_f* values of reactant **A** and product **B**. Store your TLC plate in a plastic bag.

Note 1: Product **B** may tail on the TLC plate. Therefore, avoid excessive loading of the sample.



Note 2: In some cases, two additional spots of side products of a very low intensity may be seen in combined organic phase **O1** and **O2**. In this case, calculate the R_f value for the most intense spot(s).

Note 3: If the organic layer **O2** still contains both starting material **A** and product **B**, repeat the extraction with the Na_2CO_3 solution and water (steps No. II.5 and II.6). In this case, submit also another TLC plate after the repeated extraction (Plate 2), spotting only standard **A** and organic phase **O2**. Mark number **2** in a circle and your student code on the top of this TLC plate. Use a fresh batch of eluent to develop TLC Plate 2.

P1.2 Answer the following questions about your Plate(s). From Plate 1, calculate the R_f values of standard **A** and product **B**. Provide the results rounded to 2 decimal places.

Based on the TLC analysis, your organic layer O1 contains:		
	YES	NO
Starting material A	<input type="checkbox"/>	<input type="checkbox"/>
Product B	<input type="checkbox"/>	<input type="checkbox"/>
<p><i>0.5 point for correct observation about starting material on Plate 1 (in accordance with TLC)</i> <i>0.5 point for correct observation about product B (in accordance with TLC)</i></p>		
Based on the TLC analysis, your final organic layer O2 contains:		
	YES	NO
Starting material A	<input type="checkbox"/>	<input type="checkbox"/>
Product B	<input type="checkbox"/>	<input type="checkbox"/>
<p><i>0.5 point for correct observation about starting material on final plate (in accordance with TLC)</i> <i>0.5 point for correct observation about product B (in accordance with TLC)</i></p>		
<p><i>Max 2 points for the correct preparation and development of the TLC plate 1: (labelling of the plate with number 1 and student code, start line and eluent front line, initial position of the spots, labels of the spots, developed spots in circles) -0.5 points for any from the above missing, no negative total points</i></p>		
<p>Calculation of the $R_f(\mathbf{A})$ = distance of the spot from start line/distance between the start and eluent front lines $R_f(\mathbf{A})$ = reported by the student $R_f(\mathbf{A})^*$ R_f value calculated by the Scientific Committee (SciC) for the starting material based on the submitted TLC plate 1 1 point for the calculation of the R_f value 1 point for the agreement with the SciC result: $R_f(\mathbf{A})^* + 0.02 \geq R_f(\mathbf{A}) \geq R_f(\mathbf{A})^* - 0.02$ 1 point $R_f(\mathbf{A})^* + 0.02 > R_f(\mathbf{A})$ 0 points $R_f(\mathbf{A})^* - 0.02 < R_f(\mathbf{A})$ 0 points</p>		
<p><i>Master value (MV) = 0.67 (determined from parallel data collected on practical exam day) Max 4 points for the calculated R_f value $MV - 0.07 \leq R_f(\mathbf{A})^* \leq MV + 0.07$ 4 points $MV - 0.07 > R_f(\mathbf{A})^* > MV - 0.14$</i></p>		
<p style="text-align: center;"><i>Number of points = $\left(\frac{R_f(\mathbf{A})^* - (MV - 0.14)}{0.07} \right) \times 4$ points</i></p>		
<p>$MV + 0.07 < R_f(\mathbf{A})^* < MV + 0.14$</p>		



$$\text{Number of points} = \left(\frac{MV + 0.14 - R_f(\mathbf{A})^*}{0.07} \right) \times 4 \text{ points}$$

$MV + 0.14 \leq R_f(\mathbf{A})^*$ 0 points

$MV - 0.14 \geq R_f(\mathbf{A})^*$ 0 points

Calculation of the $R_f(\mathbf{B})$ = distance of the spot from start line/distance between the start and eluent front lines

$R_f(\mathbf{B})$ = reported by the student

$R_f(\mathbf{B})^*$ R_f value calculated by the Scientific Committee (SciC) for product **B** based on the submitted TLC plate 1

1 point for the calculation of the R_f value

1 point for the agreement of the student's and SciC result

$R_f(\mathbf{B})^* + 0.02 \geq R_f(\mathbf{B}) \geq R_f(\mathbf{B})^* - 0.02$ 1 point

$R_f(\mathbf{B})^* + 0.02 > R_f(\mathbf{B})$ 0 point

$R_f(\mathbf{B})^* - 0.02 < R_f(\mathbf{B})$ 0 point

Master value (MV) = 0.12 (determined from parallel data collected on practical exam day)

Max 4 points for the calculated R_f value

$MV + 0.05 \geq R_f(\mathbf{B})^* \geq MV - 0.05$ 4 points

$MV - 0.05 > R_f(\mathbf{B})^* > MV - 0.10$

$$\text{Number of points} = \frac{R_f(\mathbf{B})^* - (MV - 0.10)}{0.05} \times 4 \text{ points}$$

$MV + 0.05 < R_f(\mathbf{B})^* < MV + 0.10$

$$\text{Number of points} = \frac{MV + 0.10 - R_f(\mathbf{B})^*}{0.05} \times 4 \text{ points}$$

$R_f(\mathbf{B})^* \leq MV + 0.10$ 0 points

$MV - 0.10 \leq R_f(\mathbf{B})^*$ 0 points

III. Reaction with Brady's reagent

Attention: Use gloves! Brady's reagent stains skin and all surfaces. Wash any spots immediately with ethanol! Change your gloves if necessary.

Preheat the water bath to 80 °C. Insert a magnetic stir bar into the 50 cm³ ground-joint Erlenmeyer flask containing the organic phase **O2** from step II.6 and add 0.300 g of 2,4-dinitrophenylhydrazine (**DNPH**). In a graduated cylinder, measure 10 cm³ of ethanol. Using a glass Pasteur pipette, rinse the glass vial with 5 × 2 cm³ of ethanol to transfer all of the **DNPH** into the Erlenmeyer flask. Place the Erlenmeyer flask into the hot water bath, attach a reflux condenser (similar setup as in Figure 1) rinsed with ethanol. Through the top opening of the condenser, add 3 cm³ of 20% HCl using a funnel and stir the reaction mixture at 80 °C for 2 minutes. Fine orange crystals of product **C** start to form. Then turn off the heating of the hotplate stirrer. Lift the reaction flask above the water bath. (*Caution!* Touch only the clamps, the flask is hot.) Allow the reaction mixture to cool down for 15 min and then place it into a cold water bath (prepared by pouring cold tap water in a 150 cm³ beaker).

IV. Isolation of the products

1. Check the pH of the combined aqueous phase from step No. II.6. Acidify it by carefully adding 20% HCl solution, stirring the mixture with a glass rod (ca. 2 cm³ of the HCl solution should be required), to the final pH of 2 (check with pH indicator strips). A white precipitate of product **B** is formed.



2. Set up a vacuum filtration apparatus (Figure 3) using a glass fritted funnel with porosity **S2** (with white label) and secure it to a laboratory stand with a small clamp. Connect the suction flask to the vacuum source. Pour the suspension of product **B** (step No. IV.1) into the fritted funnel, let the solid set down, and then open the vacuum valve. *Caution:* notify the lab assistant before and after handling the valve! Wash the solid twice with 6 cm³ of deionized water, until the pH of the dropping filtrate is about 6. Let air suck through the precipitate for 5 minutes to pre-dry the product. Disconnect the vacuum source. Use the spatula to transfer white product B to a glass vial labelled **Student code B** and leave it uncovered on the bench to dry. Discard the filtrate to the sink drain and wash the suction flask.

Note: Be careful not to scratch the fritted glass into your product!

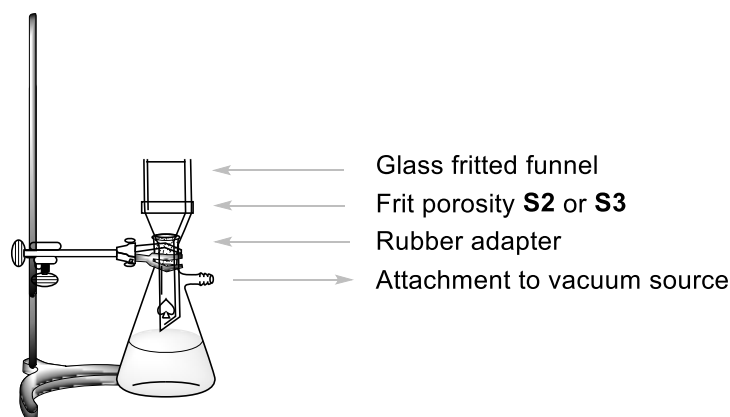

Figure 3. Setup for suction filtration.

3. Set up a vacuum filtration apparatus with a glass fritted funnel with porosity **S3** (with an orange label) similarly as in IV.2. Pour the suspension of product **C** (step No. III) into the fritted funnel, wait for a minute, and then open the vacuum valve. Do NOT stir or scratch the solid with the spatula while filtering and washing, otherwise the solid may go through the filter. Wash the precipitate three times with 5 cm³ of ethanol (15 cm³ in total) until neutral pH of the dropping filtrate is reached. Let air suck through the precipitate for 5 minutes. Disconnect the vacuum source. Use the spatula to transfer orange product C to a glass vial labelled **Student code C** and leave it uncovered on the bench to dry. Collect the filtrate into **Organic waste** bottle.

Note: If the product goes through the fritted funnel, filter the suspension once more. If the product still goes through, contact the lab assistant.

Your lab assistant will pick up following items and sign your answer sheet.

- Glass vials labelled **Student code B** and **C** with your products
- TLC plates in a zipped bag labelled with your **Student code**

Submitted items:

- Product **B**
- Product **C**
- TLC Plate 1
- TLC Plate 2 (optional)

Signatures:

Student

Lab assistant



Marking notes for evaluation of the yields and product quality

Combined yield of product B and C max 20 points

100% < y (after extended drying will be analyzed by SciC: NMR and insoluble residue).

89.0% ≤ y ≤ 100.0% 20 points

y < 89.0% linear dependence:

$$\text{Number of points} = \frac{(\% \text{ C} + \% \text{ B}) \times 20 \text{ points}}{89.0\%}$$

Products quality total max 10 points

Compound B starting point of melting and melting point interval

Starting point of melting of compound B (max 4 points)

m.p. > 186.8 °C Will be evaluated for composition by SciC.

186.8 °C ≥ m.p. ≥ 183.2 °C 4 points

183.2 °C > m.p. > 181.0 °C

$$\text{Number of points} = 4 \times \left(\frac{m.p.(\text{B}) - 181.0 \text{ °C}}{2.2 \text{ °C}} \right)$$

m.p. ≤ 181.0 °C 0 points

NMR spectrum of the sample will be recorded if the m.p. starts below 181.0 °C. Reduction of the points for the yield will be applied according to the contents of impurities based on NMR spectra. Solubility test of the sample will be performed if the sample doesn't melt completely above 190 °C. Reduction of the points for the yield will be applied according to the contents of insoluble impurities.

Melting point interval of compound B will be evaluated only if any points were granted for the starting point of melting (max 4 points)

Interval ≤ 3.1 °C 4 points

3.1 °C < interval < 5.1 °C

$$\text{Number of points} = 4 \times \left(\frac{5.1 \text{ °C} - \text{interval}}{2.0 \text{ °C}} \right)$$

Interval ≥ 5.1 °C 0 points

Purity of compound C (max 2 points)

Qualitative check by the determination of the melting point 240 °C < m.p. < 275 °C. The sample should not melt below 240 °C (1 point) and no solid residue should remain at 275 °C (1 point).

NMR spectrum of the sample will be recorded if the m.p. starts below 240.0 °C. Reduction of the points for the yield will be applied according to the contents of impurities based on NMR spectra. If more than 10% of other compounds than the product are present, 0 points will be given for the yield of product C.

Solubility test of the sample will be performed if the sample doesn't melt completely above 275 °C. Reduction of the points for the yield will be applied according to the contents of impurities based on solubility test. If more than 10% of insoluble impurity is present, 0 points will be given for the yield of product C.



Practical Problem P2	Question	2.1	2.2	2.3	2.4	2.5	2.6	Total
	13% of the total	Points	30	30	7	3	4	6
	Score							

Problem P2. A glowing clock reaction

Luminol is a well-known source of chemiluminescence. In the presence of a suitable redox catalyst, e.g. Cu^{2+} , it may react with oxidizing agents, most commonly H_2O_2 , forming products in excited electronic states. These release the excess energy by the emission of blue light:

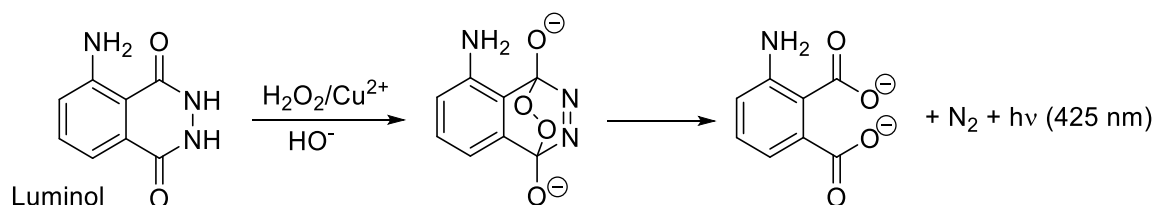

The procedure may be modified into a clock reaction, in which the light appears after a certain induction time. By adding cysteine, Cu(II) is reduced to Cu(I) and captured in a Cu(I) –cysteine complex that does not facilitate the luminol oxidation. However, the inhibition is only temporary. A cycle of reactions fuelled by H_2O_2 leads to the gradual oxidation of cysteine:

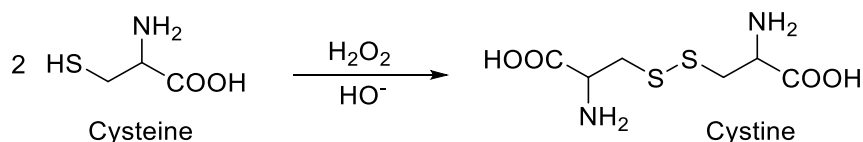

Eventually, all cysteine is consumed, Cu(I) is reoxidized to Cu(II) , and its catalytic activity is restored. This is indicated by a flash of blue chemiluminescence. The time it takes for the flash to appear can be used to study the rates of the Cu -catalyzed cysteine oxidation.

Procedure

Caution: Always keep all your solutions and pipettes away from hotplates!

Reasonable temperature changes are not a problem, because your results will be marked based on the actual reaction temperatures that you report. You will not lose any points if your data is recorded at various temperatures. However, you must avoid excessive heat, e.g. placing the solutions or the pipettes near a hotplate.

Note: Report all the values with the requested number of significant figures or decimal places. Excessive rounding may make it impossible to distinguish a correct answer from an incorrect one.

General structure of the experiment

In Part I, you will dilute two stock solutions that are provided as concentrates. In Part II, you will measure the reaction times of the clock reaction for two different concentration sets, as defined in the table below:



	Volume in the black test tube			In the centrifuge tube	
	Water	Luminol in NaOH	Cys dil.	Cu	H ₂ O ₂ dil.
Conc. set #1	3.00 cm ³	2.50 cm ³	3.30 cm ³	0.50 cm ³	0.70 cm ³
Conc. set #2	3.30 cm ³	2.50 cm ³	3.30 cm ³	0.50 cm ³	0.40 cm ³

It is recommended that before you start measuring the data to be graded, you should get familiar with the procedure in a trial run.

Because the reaction rate depends on temperature, you must record the actual temperatures in all replicates. The temperatures in the reaction mixtures should be measured IMMEDIATELY AFTER you have recorded the reaction time required to produce the blue flash.

In data evaluation, each temperature recorded from the thermometer's display must be corrected by summing it with the thermometer's calibration constant. This constant is printed on a piece of paper in the basket for Problem 2.

Then, each reaction time $t(x\text{ }^\circ\text{C})$ observed at $x\text{ }^\circ\text{C}$ (corrected) must be converted to the time $t(25\text{ }^\circ\text{C})$ that would be observed at $25\text{ }^\circ\text{C}$. This normalization of reaction times to $25\text{ }^\circ\text{C}$ is a simple multiplication of $t(x\text{ }^\circ\text{C})$ with a normalization coefficient $n_{x \rightarrow 25}$:

$$t(25\text{ }^\circ\text{C}) = n_{x \rightarrow 25} t(x\text{ }^\circ\text{C})$$

The values of the normalization coefficients $n_{x \rightarrow 25}$ corresponding to various temperatures are listed in Table P2 at the end of this task.

I. Dilution of the concentrated stock solutions

Solutions of H₂O₂ (2.00 mol dm⁻³) and cysteine (0.100 mol dm⁻³) are provided as concentrates, labelled **H₂O₂ conc.** and **Cys conc.** Using the 5 cm³ bulb pipette and the 50 cm³ volumetric flask, dilute 5.00 cm³ of each to 50.00 cm³ with deionized water and store the diluted solution in the bottles labelled **H₂O₂ dil.** and **Cys dil.**

For measuring the solution volumes in the following steps, assign one graduated pipette for each of the bottles. The 5 cm³ pipettes are for **Luminol in NaOH**, **Cys dil.**, and **Water**. The 1 cm³ pipettes are for **Cu** (2.00 mmol dm⁻³) and **H₂O₂ dil.**

II. The clock reaction procedure

Note: Read the entire Section II carefully before starting the experiment.

- Place the black test tube inside the Erlenmeyer flask serving as a stand. Using the assigned pipettes, charge the test tube with the prescribed volumes of **Water**, **Luminol in NaOH** and **Cys dil.** solution.
- Place the small centrifuge tube inside the small plastic beaker and charge it with the prescribed volumes of **Cu** solution and **H₂O₂ dil.** solution.
- Without delay**, insert the small centrifuge tube inside the black test tube – **gently, without mixing** the two solutions!



- Close the test tube with its screw-on cap. Make sure that the tube is closed tightly, because you will be shaking it. **Caution: Do not force the cap beyond its end-point**, because the tube will start leaking. If this happens, you must ask for a replacement immediately (penalty rules apply).
- Have the stopwatch ready in your hand, in timing mode. The moment you begin shaking the test tube, start timing. You must shake vigorously during the initial 10 seconds, so that the two solutions mix perfectly. It is crucial that you do not cut down the shaking time.
- Return the test tube into the Erlenmeyer flask, open the lid and watch the solution inside closely. It may help to shield away the daylight with your hand. Eventually, you will see a flash of blue light through the whole solution. At that moment, stop timing.
- Immediately, insert the metal probe of the digital thermometer into the black test tube. Wait for the reading to stabilize (typically 10–30 s) and record the reaction time and the reaction temperature.
- Using tweezers, remove the small centrifuge tube from the black test tube. After each experiment, empty and wash both tubes and dry them with paper wipes.

Measured data and their evaluation

P2.1 In the following table, record your experimental results for concentration set #1. To the displayed temperature add the thermometer's calibration constant. Look up the value of the normalization coefficient $n_{x \rightarrow 25}$ for each temperature in Table P2 and calculate the reaction times normalized to 25 °C. In an unlikely case that your temperatures are not listed in Table P2, get the value of $n_{x \rightarrow 25}$ from the lab assistant.

Note: Just as the tolerance for correct values in titration is $\pm 0.1 \text{ cm}^3$, the tolerance for correct values of the normalized times in the concentration set #1 is $\pm 2.3 \text{ s}$.

(Use as many replicates as you consider necessary, you do not need to fill in all the rows. Points will be awarded for the accepted value only.)

	Repli- cate	Reaction time [s] 1 decimal place	Displayed temperature [°C] 1 decimal place	Corrected temperature [°C] 1 decimal place	Reaction time normalized to 25 °C [s] 3 significant figures
Conc. set #1	1	57.1	27.5	27.4	68.3
	2	56.0	27.7	27.6	68.0
	3	55.7	27.8	27.7	68.2
	Accepted value of the normalized reaction time for concentration set #1				



P2.2 In the following table, record your experimental results, the corrected temperature and calculate the reaction times normalized to 25 °C for concentration set #2.

Note: Just as the tolerance for correct values in titration is $\pm 0.1 \text{ cm}^3$, the tolerance for the correct values of the normalized times in the concentration set #2 is $\pm 3.0 \text{ s}$.

(Use as many replicates as you consider necessary; you do not need to fill in all the rows. Points will be awarded for the accepted value only.)

	Repli- cate	Reaction time [s] 1 decimal place	Displayed temperature [°C] 1 decimal place	Corrected temperature [°C] 1 decimal place	Reaction time normalized to 25 °C [s] 3 significant figures
Conc. set #2	1	71.9	27.9	27.8	86.6
	2	70.6	27.9	27.8	85.1
	3	72.5	27.8	27.7	86.8
	Accepted value of the normalized reaction time for concentration set #2				

P2.3 Based on the procedure and on the concentrations of the stock solutions (specified in the list of chemicals and in Part I. of the Procedure), calculate the initial concentrations of cysteine, copper and H_2O_2 in both concentration sets.

Express the accepted reaction times (t_1 and t_2) from P2.1 and P2.2 in minutes and calculate the corresponding reaction rates (v_1 and v_2), expressed as the rates of the consumption of the cysteine concentration, in $\text{mmol dm}^{-3} \text{ min}^{-1}$. You can assume that the rate of cysteine consumption during the reaction is constant.

If you cannot find the reaction rates, use the value 11.50 for conc. set #1 and 5.500 for conc. set #2 in further calculations.

	Initial concentrations [mmol dm^{-3}] 3 significant figures			Accepted reaction time [min] 4 significant figures	Reaction rate [$\text{mmol dm}^{-3} \text{ min}^{-1}$] 4 significant figures
	Cysteine	Copper [Cu]	H_2O_2		
Conc. set #1	3.30	0.100	14.0	1.137	2.902
Conc. set #2			8.00	1.437	2.296



P2.4 Assuming the rate equation can be expressed as

$$v = k [\text{H}_2\text{O}_2]^p$$

use your experimental data to calculate the partial reaction order p with respect to H_2O_2 . Write down your answer with 2 decimal places and show your calculation.

Answer: $p = 0.42$

Calculation:

$$2.902 \text{ mmol dm}^{-3} \text{ min}^{-1} = k (14.0 \text{ mmol dm}^{-3})^p$$

$$2.296 \text{ mmol dm}^{-3} \text{ min}^{-1} = k (8.00 \text{ mmol dm}^{-3})^p$$

$$\frac{2.902}{2.296} = \left(\frac{14.0}{8.00}\right)^p$$

$$p = \frac{\log 1.264}{\log 1.75}$$

An expression of the rate law of cysteine consumption that is closer to reality is more complicated and takes the following form:

$$v = k_1[\text{H}_2\text{O}_2][\text{Cu}] + k_2[\text{Cu}]$$

P2.5 Using the data from P2.3, evaluate the dependence of v on $[\text{H}_2\text{O}_2]$ as a linear function to find the slope and the intercept. Write down both answers with 4 significant figures. If you cannot find constants a and b , use the value 11.50 for both a and b in further calculations.

Answers (do not include the calculation, but include units):

$$v = a[\text{H}_2\text{O}_2] + b$$

$$a = 0.1010 \text{ min}^{-1}$$

$$b = 1.488 \text{ mmol dm}^{-3} \text{ min}^{-1}$$

P2.6 Use the numeric values from P2.5 to evaluate the rate constants k_1 and k_2 . Write down their values with 3 significant figures.

Answers (including units):

$$k_1 = 1.01 \text{ min}^{-1} \text{ mmol}^{-1} \text{ dm}^3$$

$$k_2 = 14.9 \text{ min}^{-1}$$

Calculations:

$$k_1 [\text{Cu}] = a \Rightarrow k_1 = a / [\text{Cu}] = 0.1010 \text{ min}^{-1} / (0.100 \text{ mmol dm}^{-3})$$

$$k_2 [\text{Cu}] = b \Rightarrow k_2 = b / [\text{Cu}] = 1.488 \text{ mmol dm}^{-3} \text{ min}^{-1} / (0.100 \text{ mmol dm}^{-3})$$



Marking notes

Incorrect number of significant figures and decimal places will not be penalized.

P2.1 *Maximum 30 points, evaluated as follows:*

- 1) The reported reaction temperature is combined with the individual calibration constant of the thermometer to find the correct temperature. The correct temperature is used to normalize the reported reaction time to a value that would be measured at 25 °C, according to Table P2. This is for informative feedback on the contestant's raw data, or to be used if the Accepted Value was based on incorrect normalization – see point 4).*
- 2) The interval of Accepted Values deserving full marks (30 points) is the interval of answers collected when the procedure is performed correctly:
Master Value (determined in parallel experiments during the exam): 67.7 s.
The width of the full-marks interval (determined from a sample of 95 results from students trained to perform the procedure correctly): $MV \pm 3.5\%$ (± 2.4 s).*
- 3) Values not totally correct should receive less than full marks. The number of points received for an incorrect answer decreases linearly with the distance from the interval delineating correct answers. The minimum of 0 points is for unacceptably incorrect values, i.e. beyond $MV \pm 7.0\%$ (± 4.8 s).*
- 4) If contestant's calculation of the corrected temperature and of the normalized reaction time is missing or involves errors, a substitute Accepted Value is taken for grading. This is based on the correctly normalized reaction times calculated from contestant's raw data - see point 1), following the contestant's choice of Accepted Value or taking the mean if the choice cannot be identified.*

P2.2 *Maximum 30 points, evaluated as in P2.1:*

*Master Value (determined in parallel experiments during the exam): 88.9 s.
Full marks (determined as for P2.1): within $MV \pm 3.5\%$ (± 3.1 s)
0 points: beyond $MV \pm 7.0\%$ (± 6.2 s)*

P2.3 *Maximum 7 points total:*

*1 point for each correct concentration, 0 points for incorrect answers
0.5 point for each correct conversion of a reaction time to minutes, 0 points for incorrect answers
1 point for each correct calculation of the rate of cysteine consumption, 0 points for incorrect answers*

P2.4 *Maximum 3 points total:*

*2 points for correct calculation (showing at least one formula that can be evaluated to yield the result)
1 point for correct value of the result*

P2.5 *Maximum 4 points total:*

2 points for each correctly calculated parameter including correct unit, 1 point for each correct numerical value with incorrect or no unit, 1 point for each incorrect numeric value including correct unit, 0 points for each incorrect value with incorrect or no unit

P2.6 *Maximum 6 points total:*

*2 points for correct calculation (showing the formulas that can be evaluated to yield the results)
2 points for each correct rate constant including correct units, 1 point for each correct numerical value with incorrect or no unit, 1 point for each incorrect numeric value including correct unit, 0 points for each incorrect value with incorrect or no unit.*



Table P2. Normalization coefficients $n_{x \rightarrow 25}$ for converting reaction times measured at various temperatures to times representing the reactions at 25.0 °C.

Temp. °C	Set #1	Set #2
22.0	0.8017	0.8221
22.1	0.8076	0.8274
22.2	0.8135	0.8328
22.3	0.8195	0.8382
22.4	0.8255	0.8437
22.5	0.8316	0.8492
22.6	0.8377	0.8547
22.7	0.8438	0.8603
22.8	0.8500	0.8659
22.9	0.8563	0.8715
23.0	0.8626	0.8772
23.1	0.8690	0.8829
23.2	0.8754	0.8887
23.3	0.8818	0.8945
23.4	0.8884	0.9004
23.5	0.8949	0.9063
23.6	0.9015	0.9122
23.7	0.9082	0.9182
23.8	0.9149	0.9242
23.9	0.9217	0.9303
24.0	0.9285	0.9364
24.1	0.9354	0.9425
24.2	0.9424	0.9487
24.3	0.9494	0.9550
24.4	0.9564	0.9613
24.5	0.9636	0.9676
24.6	0.9707	0.9740
24.7	0.9780	0.9804
24.8	0.9852	0.9869
24.9	0.9926	0.9934
25.0	1.0000	1.0000
25.1	1.0075	1.0066
25.2	1.0150	1.0133
25.3	1.0226	1.0200
25.4	1.0302	1.0268
25.5	1.0379	1.0336
25.6	1.0457	1.0404

Temp. °C	Set #1	Set #2
25.7	1.0536	1.0474
25.8	1.0614	1.0543
25.9	1.0694	1.0613
26.0	1.0774	1.0684
26.1	1.0855	1.0755
26.2	1.0937	1.0827
26.3	1.1019	1.0899
26.4	1.1102	1.0972
26.5	1.1186	1.1045
26.6	1.1270	1.1119
26.7	1.1355	1.1194
26.8	1.1441	1.1268
26.9	1.1527	1.1344
27.0	1.1614	1.1420
27.1	1.1702	1.1497
27.2	1.1790	1.1574
27.3	1.1879	1.1651
27.4	1.1969	1.1730
27.5	1.2060	1.1809
27.6	1.2151	1.1888
27.7	1.2243	1.1968
27.8	1.2336	1.2049
27.9	1.2430	1.2130
28.0	1.2524	1.2212
28.1	1.2619	1.2294
28.2	1.2715	1.2377
28.3	1.2812	1.2461
28.4	1.2909	1.2545
28.5	1.3008	1.2630
28.6	1.3107	1.2716
28.7	1.3207	1.2802
28.8	1.3307	1.2889
28.9	1.3409	1.2976
29.0	1.3511	1.3064
29.1	1.3615	1.3153
29.2	1.3719	1.3243
29.3	1.3823	1.3333

Temp. °C	Set #1	Set #2
29.4	1.3929	1.3424
29.5	1.4036	1.3515
29.6	1.4143	1.3607
29.7	1.4252	1.3700
29.8	1.4361	1.3793
29.9	1.4471	1.3888
30.0	1.4582	1.3983
30.1	1.4694	1.4078
30.2	1.4807	1.4175
30.3	1.4921	1.4272
30.4	1.5035	1.4369
30.5	1.5151	1.4468
30.6	1.5267	1.4567
30.7	1.5385	1.4667
30.8	1.5503	1.4768
30.9	1.5623	1.4869
31.0	1.5743	1.4972
31.1	1.5865	1.5075
31.2	1.5987	1.5179
31.3	1.6111	1.5283
31.4	1.6235	1.5388
31.5	1.6360	1.5495
31.6	1.6487	1.5602
31.7	1.6614	1.5709
31.8	1.6743	1.5818
31.9	1.6872	1.5927
32.0	1.7003	1.6038
32.1	1.7135	1.6149
32.2	1.7268	1.6260
32.3	1.7402	1.6373
32.4	1.7536	1.6487
32.5	1.7673	1.6601
32.6	1.7810	1.6716
32.7	1.7948	1.6833
32.8	1.8087	1.6950
32.9	1.8228	1.7068
33.0	1.8370	1.7186



Practical Problem 3 13% of the total	Question	3.1	3.2	3.3	3.4	3.5	
	Points	3	20	2	2	16	
	Score						
	Question	3.6	3.7	3.8	3.9	3.10	Total
	Points	4	20	2	4	2	75
	Score						

Problem P3. Mineral water identification

Many mineral and thermal water springs are registered in Slovakia. Mineral waters with a balanced composition and natural or modified carbon dioxide content are sold for daily consumption. These waters do not contain nitrites, nitrates, phosphates, fluorides and sulfides and are also free of iron and manganese.

The mass concentration of the most important ions is reported on the packaging.

Your task is to identify the trade brand (from Table P3.1) of your mineral water sample.

Note: CO₂ has been removed from the sample.

Table P3.1. Mass concentrations of ions in selected Slovak mineral waters. (As reported by the supplier.)

No.	Trade brand	Mass concentration of ion, mg dm ⁻³						
		Ca ²⁺	Mg ²⁺	Na ⁺	K ⁺	Cl ⁻	SO ₄ ²⁻	HCO ₃ ⁻
1	Kláštorná	290	74	71	16	15	89	1 341
2	Budišská	200	50	445	50	25	433	1 535
3	Baldovská	378	94	90	0	78	215	1 557
4	Santovka	215	67	380	45	177	250	1 462
5	Slatina	100	45	166	40	104	168	653
6	Fatra	45	48	550	16	36	111	1 693
7	Ľubovnianska	152	173	174	5	10	20	1 739
8	Gemerka	376	115	85	0	30	257	1 532
9	Salvator	473	161	214	30	116	124	2 585
10	Brusnianska	305	101	187	35	59	774	884
11	Maxia	436	136	107	18	37	379	1 715

*Notes:*

- Use the prescribed symbols in the notations of calculations.
- You are provided with a swollen cation exchange resin (**Catex**) in its H⁺ form. Use a thick stem Pasteur pipette for transferring it. You can add more deionized water to the resin if necessary (it should not dry out).
- Concentrations of the standard solutions:
 $c(\text{NaOH}) = 0.2660 \text{ mol dm}^{-3}$ $c(\text{EDTA}) = 5.965 \times 10^{-3} \text{ mol dm}^{-3}$

Procedure

1.a Measure 5.00 cm³ of the catex into the graduated cylinder (volume V1). Then using deionized water transfer the catex quantitatively into a titration flask. Add an appropriate amount of deionized water so that the suspension can be swirled well and the colour of the solution over the catex can be observed.

1.b Add 3–4 drops of the bromothymol blue indicator (**BTB**) and about 1 g (half a spoon) of solid NaCl. When NaCl dissolves, titrate all the suspension with the standard sodium hydroxide solution (volume V2) from yellow to blue. Close to the equivalence point, titrate slowly and swirl well so that any analyte inside the catex skeleton may diffuse into the solution. Repeat the experiment as necessary.

1.c After the titration, decant and discard most of the aqueous solution in the titration flask above the catex and transfer the suspension to the **Waste catex** container.

P3.1 Write down all the chemical reactions which occur in Step 1. Use R–H as a formula for the catex in a H⁺ form and HInd for the indicator.

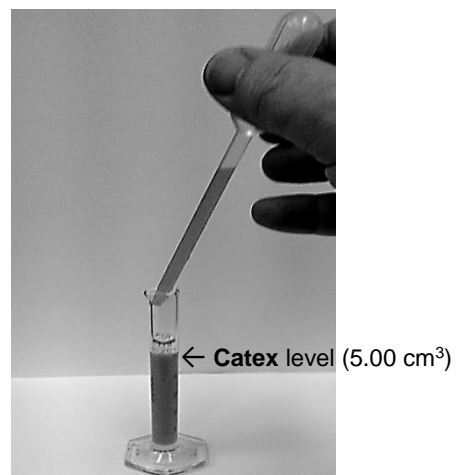
**Ion exchange**

1 point for the correct equation

Neutralization

1 point for the correct equation

Indication

1 point for the correct equation



P3.2 Enter the experimental and accepted values from Step 1 into the table.

(You do not need to fill in all the rows.)

Analysis No.	Catex volume V1 [cm ³]	NaOH consumption V2 [cm ³]
1	5.00	e.g. 19.00
2		e.g. 19.50
3		e.g. 19.70
Accepted value V2 4 significant figures		e.g. 19.40

Maximum 20 points based on the agreement between the master and accepted values V2 (specified in Marking notes; the number of replications is not evaluated).

P3.3 Using the accepted value of V2, calculate the ion exchange volume capacity $Q_v(\text{H}^+)$ in mmol cm^{-3} .

Calculation:

$$Q_v(\text{H}^+) = \frac{V2 \times c(\text{NaOH})}{V1} = \frac{19.40 \text{ cm}^3 \times 0.2660 \text{ mol dm}^{-3}}{5.0 \text{ cm}^3} = 1.032 \text{ mmol cm}^{-3}$$

1 point for the correct calculation procedure

1 point for correct result

If you cannot find the $Q_v(\text{H}^+)$ value, use $1.40 \text{ mmol cm}^{-3}$ for further calculations.

- 2.a Using a graduated cylinder, measure 5.00 cm^3 of the swollen catex (volume V3). Transfer the measured catex quantitatively into the 250 cm^3 beaker. Using a pipette, add 50.00 cm^3 of your sample (volume V4). Swirl the mixture occasionally for about 5 minutes. Use the Erlenmeyer flask as a stand for the funnel and to collect the filtrate. Then filter the catex through a fritted funnel (porosity **S1**) and wash it with deionized water to a neutral pH (check with pH paper). Discard the filtrate.
- 2.b Using deionized water, transfer the catex quantitatively from the funnel into a titration flask and discard the filtrate.
- 2.c Add 3–4 drops of bromothymol blue indicator and about 1 g (half a spoon) of solid NaCl and titrate the suspension with the standard sodium hydroxide solution (volume V5) from yellow to blue. Repeat the experiment as necessary.
- 2.d After the titration, decant and discard most of the aqueous solution in the titration flask above the catex and transfer the suspension to the **Waste catex** container.



P3.4 Write down the equations for the ion exchange reactions. Monovalent and divalent ions should be abbreviated M^+ and M^{2+} , respectively.

Ion exchange from the sample



2 points – 1 point for each correct equation or 2 points for the correct general equation with M^{n+}

P3.5 Enter the experimental and accepted values from Step 2 into the table.

(You do not need to fill in all the rows.)

Analysis No.	Catex volume $V3$ [cm ³]	Sample volume $V4$ [cm ³]	NaOH consumption $V5$ [cm ³]
1	5.00	50.00	e.g. 13.00
2			e.g. 13.20
3			e.g. 13.10
Accepted value $V5$ 4 significant figures			e.g. 13.10

Maximum 16 points based on the agreement between the master and accepted values $V5$ (specified in Marking notes; the number of replications is not evaluated).

P3.6 Consider that all the ions in your solution are M^+ ions. For the accepted value of $V5$, calculate the total amount of cations (as M^+ molar concentration) in 1 dm³ of mineral water. Show the calculation of the total equivalent concentration of cations, $c^*(M^+)$ in mmol dm⁻³.

Calculation:

$$c^*(M^+) = \frac{V3 \times Q_v(H^+)_{\text{ionex}} - V5 \times c(\text{NaOH})}{V4}$$

$$c^*(M^+) = \frac{5.00 \text{ cm}^3 \times 1.032 \text{ mol dm}^{-3} - 13.10 \text{ cm}^3 \times 0.2660 \text{ mol dm}^{-3}}{50.00 \text{ cm}^3}$$

$$c^*(M^+) = 33.51 \text{ mmol dm}^{-3}$$

3 points for the correct calculation procedure

1 point for correct result including unit

If you cannot find the $c^*(M^+)$ value, use 35.00 mmol dm⁻³ for further procedure.



In the next step, you are going to perform complexometric analysis to determine the concentration of Ca^{2+} and Mg^{2+} together (hereinafter written as M^{2+}).

3. Pipette 10.00 cm^3 (V_6) of the sample into the titration flask and add ca. 25 cm^3 of deionized water. Adjust pH by adding 3 cm^3 of the buffer solution. Add some Eriochrome black T indicator (**EBT**, on the tip of the spatula) and titrate with the standard EDTA solution from wine red to blue (V_7).

P3.7 Enter the experimental and accepted values from Step 3 into the table.

(You do not need to fill in all the rows)

Analysis No.	Sample volume V_6 [cm^3]	EDTA consumption, V_7 [cm^3]
1	10.00	e.g. 14.20
2		e.g. 14.25
3		e.g. 14.25
Accepted value V_7 4 significant figures		e.g. 14.25

Maximum 20 points based on the agreement between the master and accepted values V_7 (specified in Marking notes; the number of replications is not evaluated).

P3.8 For the accepted volume of V_7 , calculate the molar concentration of M^{2+} cations in mineral water, $c(\text{M}^{2+})$ in mmol dm^{-3} .

Calculation:

$$c(\text{M}^{2+}) = \frac{V_7 \times c(\text{EDTA})}{V_6}$$

$$c(\text{M}^{2+}) = \frac{14.25 \text{ cm}^3 \times 5.965 \text{ mmol dm}^{-3}}{10.00 \text{ cm}^3} = 8.500 \text{ mmol dm}^{-3}$$

1 point for the correct calculation procedure

1 point for correct result including unit

If you cannot find the $c(\text{M}^{2+})$ value, use $15.00 \text{ mmol dm}^{-3}$ for further solution.

4. Use Table P3.2 in next identification procedure.

P3.9 In Table P3.2, write down experimentally found values from tasks P3.6 and P3.8 and tick (✓) all the lines with approximate match ($\pm 10\%$) of the found parameter $c(\text{M}^{2+})$ and $c^*(\text{M}^+)$ with the data from the label.



Table P3.2

Mineral water		Supplier data			Match with the experiment	
No.	Trade brand	$c(\text{M}^{2+})$ [mmol dm ⁻³]	$c(\text{M}^+)$ [mmol dm ⁻³]	Total equivalent concentration of cations $c^*(\text{M}^+)$ [mmol dm ⁻³]	Conformity for $c(\text{M}^{2+})$	Conformity for $c^*(\text{M}^+)$
Your exp. values		8.50	XXX	33.51	XXX	XXX
1	Kláštorná	10.30	3.50	24.1		
2	Budišská	7.06	20.63	34.7		✓
3	Baldovská	13.32	3.91	30.5		✓
4	Santovka	8.13	17.67	33.9	✓	✓
5	Slatina	4.35	8.25	16.9		
6	Fatra	3.11	24.32	30.5		✓
7	Ľubovnianska	10.92	7.70	29.5		
8	Gemerka	14.13	3.70	32.0		✓
9	Salvator	18.46	10.07	47.0		
10	Brusnianska	11.79	9.03	32.6		✓
11	Maxia	16.50	5.11	38.1		

Maximum 4 points. For each column: 2 points if correctly marked, 1 point if partially marked.

P3.10 Based on your results, decide which mineral water is in your sample. Tick (✓) the cross-reference number(s) of the mineral water(s).

No.		Trade brand	No.		Trade brand
1		Kláštorná	7		Ľubovnianska
2		Budišská	8		Gemerka
3		Baldovská	9		Salvator
4	✓	Santovka	10		Brusnianska
5		Slatina	11		Maxia
6		Fatra	12		other

2 points if consistent with the results marked in Table 3.2 (Kláštorná or Ľubovnianska, if values from P3.6 and P3.8 are accurate)



Marking notes

P3.2 Full points if relative deviation is lower than $\pm 1.5\%$ of the master value.

Acquired points are calculated from the following equation:

$$\text{Score} = 32.0 - 8.0 \times |(V2_{\text{student}} - V2_{\text{master}}) / V2_{\text{master}}| \times 100,$$

0 points if relative deviation is higher than $\pm 4.0\%$ of the master value.

$$V2_{\text{master}} = 13.10, 17.20, \text{ or } 20.65 \text{ cm}^3$$

P3.5 Full points if relative deviation is lower than $\pm 4.0\%$ of the master value.

Acquired points are calculated from the following equation:

$$\text{Score} = 21.81818 - 1.45455 \times |(V5_{\text{student}} - V5_{\text{master}}) / V5_{\text{master}}| \times 100,$$

0 points if relative deviation is higher than $\pm 15.0\%$ of the master value.

$$V5_{\text{master}} = \text{from } 7.54 \text{ to } 16.12 \text{ cm}^3$$

P3.7 Full points if relative deviation is lower than $\pm 0.5\%$ of the master value.

Acquired points are calculated from the following equation:

$$\text{Score} = 25.0 - 10.0 \times |(V7_{\text{student}} - V7_{\text{master}}) / V7_{\text{master}}| \times 100,$$

0 points if relative deviation is higher than $\pm 2.5\%$ of the master value.

$$V7_{\text{master}} = 17.15 \text{ or } 18.41 \text{ cm}^3$$

Replaced chemicals and equipment

Item or incident	Penalty	Signature	
		Student	Lab assistant
	0 pt		